

HBC-4301A
Hot Bonding Controller

Advanced Operators Manual & Calibration



Supplied by



JR TECHNOLOGY
LIMITED

March 2009

TABLE OF CONTENTS

Table of Contents	1
1. Introduction to the Calibration Procedure	3
1.1 Equipment Required for Calibration	3
1.2 Summary of the Hardware Requiring for the Calibration	4
1.3 The Display and Keypad	5
Figure 1: Control Case Keypad and Display	5
1.4 Accessing the Calibration Menu	5
1.5 Calibration Menu Summary	6
2. Power Supply Check & Cold-Start Procedure	7
2.1 Power Supply	7
Figure 2: Position of Power Supply Test Points	7
2.2 Cold-Start Procedure	8
3. Date / Time Settings & Thermocouple Type	9
3.1 Set the Internal Clock	9
3.2 Set the Thermocouple Type	9
4. ADC Calibration	11
Figure 3: Main PCB Reference Voltage Test Points	11
Figure 4: Thermocouple Input PCB Reference Voltage Test Point	12
5. Cold Junction & Ambient Temperature Sensors	13
6. Vacuum and Pressure Sensors	15
6.1 Internal Pressure Sensor	15
6.2 Internal Vacuum Sensor	16
6.3 External Vacuum Sensor Inputs	17
7. Power Output Levels and the Vacuum Pumps	19
7.1 Heater Outputs	19
7.2 Internal Vacuum Pumps	20
Figure 5: Vacuum Pump 1 Pumping Rate Test	20
Figure 6: Vacuum Level at Specific Leak Rates	21
8. Safety Checks	23
8.1 Earth Leak Detectors (Residual Current Detectors)	23
8.2 Earth Socket	23
8.2 Other Safety Issues	23
9. Quality Control Report	25
Information Screen	25
Appendix A. HBC-4301A Calibration Check List	26

© Copyright NOVATECH CONTROLS (AUST) PTY LTD —2009

Edition - March 2009

This manual describes the notebook PC software version 1.6.2
and the control case software version 2.01, 16th July 2008

Neither the whole nor any part of the information contained in, or the product described in, this manual may be adapted or reproduced in any material form except with the prior written approval of Novatech Controls (Aust) Pty Ltd (Novatech Controls).

The product described in this manual and products for use with it are subject to continuous developments and improvement. All information of a technical nature and particulars of the product and its use (including the information in this manual) are given by Novatech Controls in good faith. However, it is acknowledged that there may be errors or omissions in this manual. A list of details of any amendments or revisions to this manual can be obtained upon request from Novatech Controls Technical Enquiries. Novatech Controls welcome comments and suggestions relating to the product and this manual.

All correspondence should be addressed to:

Technical Enquiries
Novatech Controls Pty Ltd
309 Reserve Road,
Cheltenham
Victoria 3192
Australia.

Tel: +61 3 9585 2833
Fax: +61 3 9585 2844
Email: info@novatech.com.au
Web site: <http://www.novatech.com.au/>

All maintenance and service on the product should be carried out by Novatech Controls' authorised dealers. Novatech Controls can accept no liability whatsoever for any loss or damage caused by service or maintenance by unauthorised personnel. This manual is intended only to assist the reader in the use of the product, and therefore Novatech Controls shall not be liable for any loss or damage whatsoever arising from the use of any information or particulars in, or any error or omission in, this manual, or any incorrect use of the product.

1. INTRODUCTION TO THE CALIBRATION PROCEDURE

It is recommended by the manufacturer of the HBC-4301A hot bonding controller that the calibration procedure should be carried out every 12 months.

The calibration must be done by personnel qualified to calibrate electronic instruments.

The test equipment used to do the calibration must be calibrated by a certified laboratory and be within the calibration period.

The procedure described in this document includes the calibration and a check of the functions of the HBC-4301A control case.

The calibration of the HBC-4301A control case is set from the control case by using the keypad and the display and the calibration factors are stored within the control case.

1.1 Equipment Required for Calibration

1. Ambient Temperature Sensor

RTD sensor class A.
Accuracy $\pm 0.15^{\circ}\text{C}$ @ 0°C

2. Thermocouple Output Generator with Cold Junction Compensation

Thermocouple type K and J
Range 0 to 300°C
Accuracy 0.1°C

3. Digital Multimeter

Resolution 0.01mV in the range 0 to 100mVDC
Resolution 0.1mV in the range 100 to 1000mVDC
Resolution 0.1Ω measuring resistance
Accuracy $0.05\% \pm 1$ digit

4. 4-20mA Loop Powered Calibration Device

Resolution of 0.1mA over the range 4-20mA

5. Vacuum Measuring Instrument

Resolution 0.1 kPa in the range -100kPa to 0kPa
Accuracy $0.5\% \pm 1$ digit

6. Pressurised Regulated Air Supply $\sim 500\text{kPa}$

Actual pressure should be measured and known to $\pm 5\text{kPa}$.

1.2 Summary of the Hardware Requiring for the Calibration

The HBC-4301A input measurement system uses multiple analog to digital converters (ADC) to achieve a high level of accuracy and reliability:

ADC #1 measures the thermocouple inputs

ADC #2 measures the vacuum and pressure sensors and the cold junction temperature

ADC #3 is used to measure the secondary cold junction temperature, the heatsink temperature and the case temperature.

The HBC-4301A continuously monitors itself during operation to allow for hardware error detection. It also checks its ADC's against a stable reference voltage every 30 seconds allowing for compensation in any drift that may be caused by temperature or pressure drift while in operation.

The calibration procedure is broken down into five sections.

1. Checking the DC Power Supply Voltages
2. Setting the Date / Time
3. Setting the Reference Voltages
4. Calibrating the Ambient / Cold Junction Temperature Sensors
5. Calibrating the Vacuum / Pressure System

The calibration of the ADC relies on setting of reference voltage levels in the Calibration Menu of the HBC-4301A. This enables the microcontroller to automatically compensate for drift in the electronic components between calibrations.

The calculation of the thermocouple temperature requires an accurate measurement of the temperature at the point where the thermocouple wire (or thermocouple compensating wire) is joined to copper wires. This is achieved in the HBC-4301A by using two solid-state temperature sensors mounted in thermal contact with the thermocouple input connectors.

The incoming compressed air supply and the vacuum level generated by vacuum pump #2 are measured with internal sensors. These sensors and the external vacuum sensors are measured with a separate analogue to digital converter (ADC)

1.3 The Display and Keypad

The calibration of the HBC-4301A control case is all done from the local keypad and display.

Above each key printed in **blue writing** is a description of the function of the key in **Run Mode** and below each key printed in **green writing** a description of the key function in either of the **Calibration Menu** or **Setup Menu** modes.

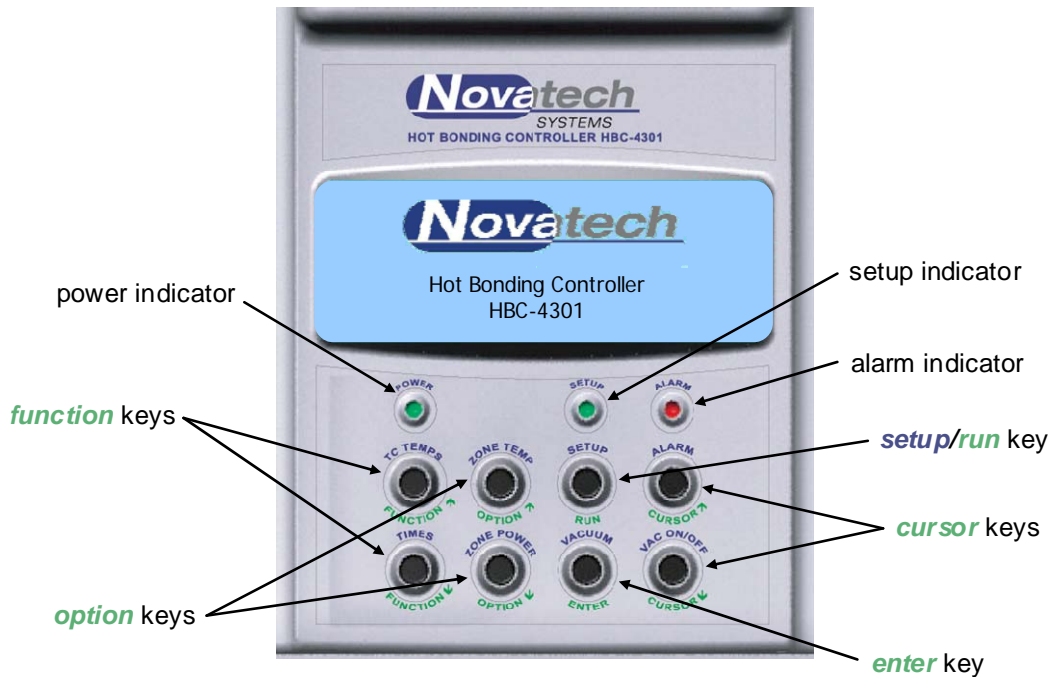

Figure 1: Control Case Keypad and Display

1.4 Accessing the Calibration Menu

The Setup Menu functions are listed in the HBC-4301A Operators Manual. The additional calibration functions that are accessed via the Calibration Menu are not normally available to the operator.

To gain access to the Calibration Menu:

1. Press and hold the **setup** key and then turn on the power. Hold the key until the words "Calibration Menu Enabled" appear on the screen (about 10 seconds)
2. Release the **setup** key and wait for the initialisation procedure to complete
3. Once in run mode press and hold the **setup** key until the display says 'Entering Calibration Menu'

The Setup Menu will appear first but if you continue to hold down the **setup** key for a few seconds the Calibration Menu will appear in its place.

To exit the Calibration Menu and return to the run mode press the **run** key.

1.5 Calibration Menu Summary

The Calibration Menu functions are –

01	Reference Voltages	253.41 mV 1165.4 mV 2481.9 mV 12.15 mV
02	Thermocouple Type	K-Type J-Type
03	Temperature Calibration	Cold Junction.1 Cold Junction.2 Ambient Temperature Heatsink
04	Internal Vacuum Calibration	Calibrate Zero Calibrate Span
05	Internal Pressure Calibration	Calibrate Zero Calibrate Span
06	Vacuum 1 Calibration	Calibrate Zero Calibrate Span
07	Vacuum 2 Calibration	Calibrate Zero Calibrate Span
08	Phase / Burst Threshold	Adjustable (0%/No phase to 100%/No burst)
09	Internal Clock Date and Time	Adjustable
10	Serial Interface	RS-485 2-wire RS-232

2. POWER SUPPLY CHECK & COLD-START PROCEDURE

2.1 Power Supply

The DC power rails used by the electronics are derived from a switch mode power supply mounted in the base of the HBC-4301A. There are labelled test points for all the DC voltages accessible under the metal cover plate on the HBC4300-1 PCB.

The test points are in the top right hand corner of the HBC4300-1 PCB, near the connector that connects the power supply to the Main PCB. The shield must be removed to gain access to these test points. They are labelled –

Check that the rails are within the following specifications by measuring from "C" to the other three pins.

VCC +5v Digital circuits	+/- 0.1v
+12v Analogue circuits	+/- 0.3v
-12v Analogue circuits	+/- 0.3v

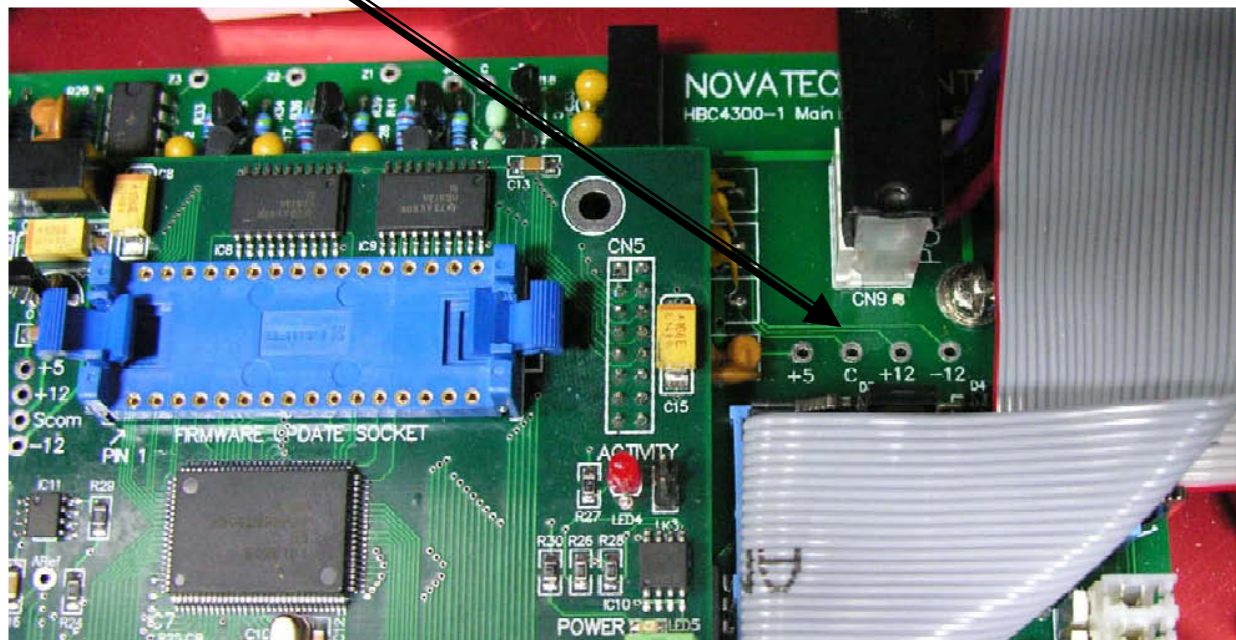

Figure 2: Position of Power Supply Test Points

2.2 Cold-Start Procedure

All the settings in the menu functions including the calibration constants are stored in a battery-backed memory module (BBRAM). The battery for this module is built into the module and cannot be changed. It has a specified life of approximately 10 years.

The control case can be returned to factory default setup and calibration by performing a **Cold-Start**. This procedure is performed when the control case is first manufactured and it should not be necessary to perform it again.

WARNING:

A Cold-Start will remove all the calibration settings and the menu options of the control case and set them all to factory defaults.

Do not do this unless there appears to be a serious problem with the control case.



1. While the power is turned off, remove the 2 screws in the front corners of the control case
2. Lift the hinged control panel up from the front using the handle near the keypad
3. Remove the 3 screws and the cover over the PCB in the rear left of the base of the control case
4. Locate the 4 way DIP switch SW1 on the top PCB.
5. Set the DIP switch #1 (COLD START) to ON (switch to the left)
6. Turn the power on to the control case with the power switch



7. Wait until the message as shown above is on the display

The memory is divided into 2 sections. One area holds the calibration data and the other the configuration of the hot bonder.

Press '**Cancel**' (Cursor up) to reset the configuration data only and not the device calibration.

Press '**Reset**' (Function up) to reset the calibration and the configuration data.

8. Set the DIP switch #1 back to OFF when the message "Turn off Cold-Start Switch" appears.
9. Turn the power off and replace the metal shield on the PCB
10. The HBC-4301A will now need calibrating if the calibration data was reset in set #7 above.

NOTE: The temperature accuracy of the HBC-4301A **without** calibration is generally +/- 3°C

3. DATE / TIME SETTINGS & THERMOCOUPLE TYPE

3.1 Set the Internal Clock

It is important to set the internal clock within the control case as the software uses this date to timestamp any alarms or errors that occur.

1. Enter the Calibration Menu and navigate to Calibration Menu #09
2. Use the *cursor* keys to select between date & time and use the *option* keys to change the date & time. Press the *enter* key to store the displayed values.

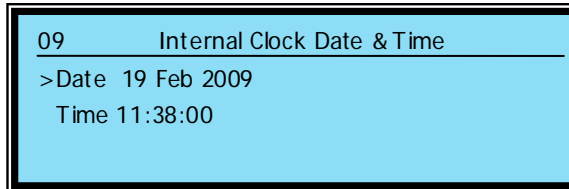

3.2 Set the Thermocouple Type

The software has been written to allow for either type K or type J thermocouples.

NOTE: The compensation materials used in the thermocouple input connectors in the HBC-4301A are intended for K-type thermocouples. Mixing of compensation materials has the potential to create temperature offset, although in this application the affect is small given that the copper interface and Cold Junction occurs almost simultaneously.

If using J-Type thermocouples you may experience an error of ~1.5°C

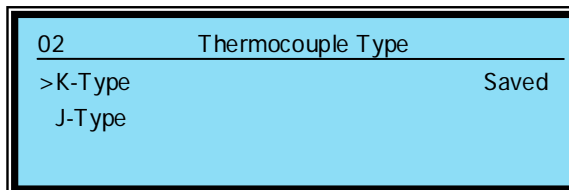

Navigate to Calibration Menu #02. Use the *cursor* or *option* keys to select the thermocouple type and press the *enter* key to save the selection.

4. ADC CALIBRATION

To calibrate the internal ADC, measure and record the reference voltage at the test points using a multimeter. Navigate to Calibration Menu #01.

01 Reference Voltages		
>Ref1	253.41 mV	Saved
Ref2	1165.4 mV	Saved
Ref3	2481.9 mV	Saved
RefTC	12.15 mV	Saved

Use the **cursor** keys to move the cursor between the four reference voltage entries. Enter the reference voltage values to match those measured using the **option** keys. When finished press the **enter** key to store the displayed values.

The word "Saved" at the end of the line indicates the values being displayed are stored in memory.

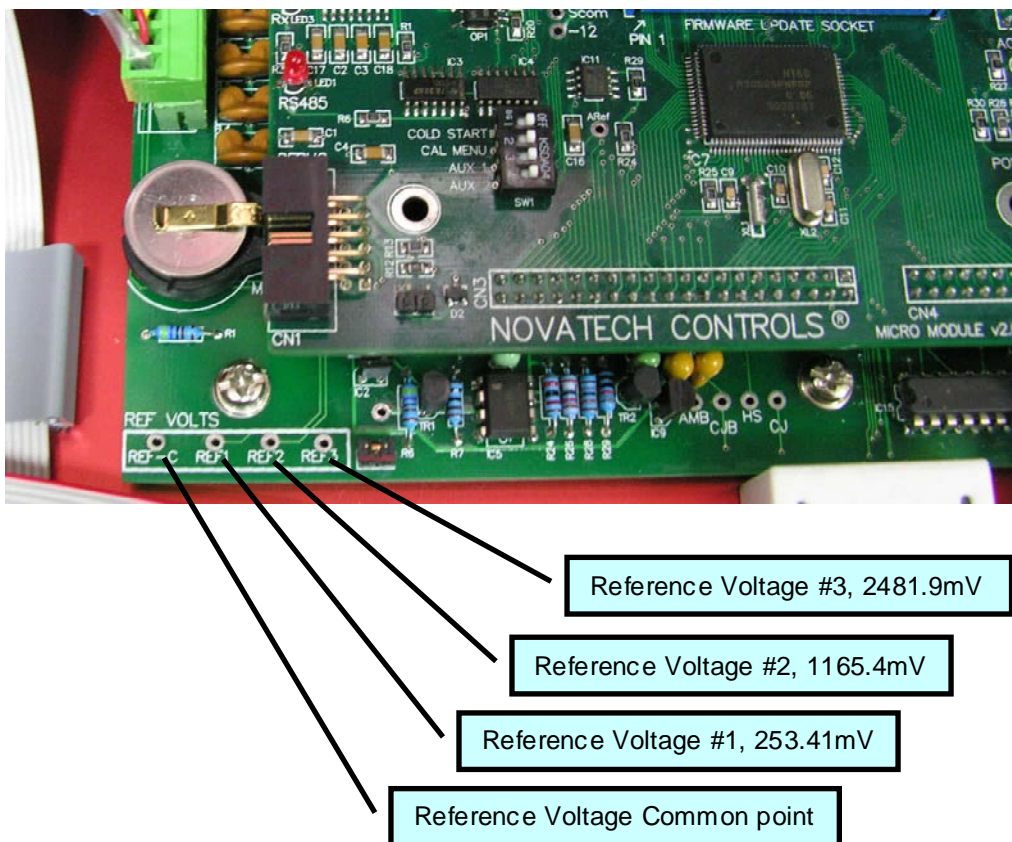

Figure 3: Main PCB Reference Voltage Test Points

The Ref #1, Ref#2 and Ref #3 test points are measured on the main PCB model HBC-4300-1. The PCB is mounted in the rear left hand corner of the base chassis under the shield in the HBC-4301A control case.

The TC reference is measured on the thermocouple input PCB model HBC-4300-3 as shown below. The PCB is mounted on the underside of the main control console in the HBC-4301A control case.

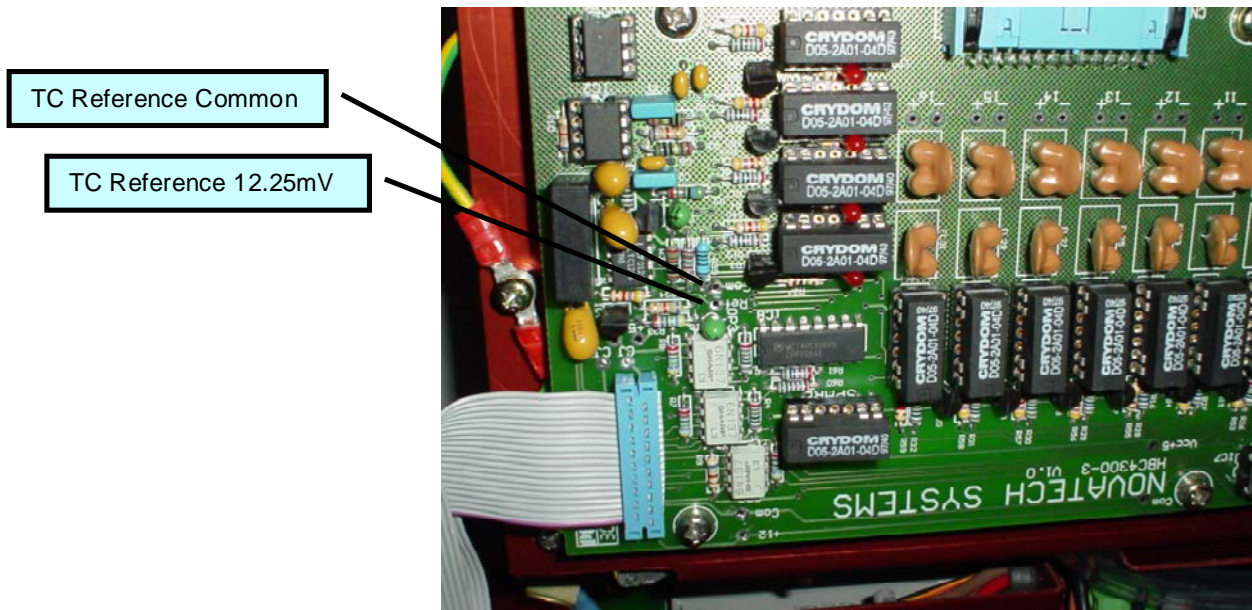

Figure 4: Thermocouple Input PCB Reference Voltage Test Point

Measure and record the thermocouple reference voltage at the test points with the multimeter. Set the number into Calibration Menu #01.

This completes the reference voltage setting and both the thermocouple ADC and the main ADC calibration. The automatic calibration software and circuitry will now maintain the accuracy of the amplifier and the ADC. It will also compensate for any drift or scale changes that might occur as a result of ambient temperature changes.

5. COLD JUNCTION & AMBIENT TEMPERATURE SENSORS

The Cold Junction and Ambient temperature sensors are a critical part of the measurement of temperature. Their calibration must be performed accurately otherwise all of the thermocouple measurements will have a temperature offset error.

The reliability of the Cold Junction temperature measurement uses two independent sensors have been integrated into the HBC-4301A. Each sensor has separate circuitry to maintain operation in the event that one should fail.

The Cold Junction temperature measurement is performed by averaging the reading from the two temperature sensors. This reading is then compared to the ambient temperature sensor providing a third level of checking. If a temperature error is detected an alarm is raised.

To calibrate the Cold Junction measurement use a calibrated temperature indicator to measure the temperature in the area between the two thermocouple input PCB's.

1. While the power is turned off, remove the 2 screws in the front corners of the control case. Lift the control panel up from the front using the handle near the keypad. Place the temperature probe into the area between the two thermocouple input PCB's. Leave the control console open for at least 30 minutes for the temperature to stabilise.
2. Turn the power on holding down the **setup** button to enable Calibration Menus. Navigate to Calibration Menu #03.

03	Temperature Calibration		
>Cold Junc.1	26.6 C	(0.0)	Saved
Cold Junc.2	27.0 C	(0.0)	Saved
Ambient	28.6 C	(0.0)	Saved
Heatsink	25.8 C	(0.0)	Saved

3. Use the **cursor** keys to move the cursor between each of the temperature sensors and the **option** keys to adjust the offset temperature up or down until the displayed temperature is the same as the independent temperature probe.
4. Press the **enter** key to store the calibration data to BBRAM.

For each temperature sensor the calibrated temperature is displayed on the left with the adjusted offset displayed in brackets on the right.

6. VACUUM AND PRESSURE SENSORS

The vacuum and pressure sensors must be calibrated independently of the ADC calibration. The calibration of the vacuum and pressure sensors and the two vacuum transducer inputs are unaffected by the ADC calibration described in Chapter 4 and must be performed in addition to the ADC calibration.

6.1 Internal Pressure Sensor

The internal pressure sensor is internally connected to the **AIR IN** quick-connect. It is used to display and monitor the external air pressure supply.

1. Start by disconnecting any external compressed air supply from the AIR IN quick connect.
2. Enter the Calibration Menu and navigate to Calibration Menu #05.

05	Internal Pressure Calibration		
>Calibrate Zero	0.0 mV		Saved
Calibrate Span	500 kPa		Saved

3. Use the **cursor** keys to select 'Calibrate Zero' and press the **enter** key. The control case will automatically read the internal pressure transducer and save this value as a zero offset.
4. Connect the external pressure hose to the AIR IN quick connect and adjust the air supply pressure to ~500kPa.
5. Use the **cursor** keys to select 'Calibrate Span', adjust the displayed value using the **option** keys until the displayed value matches the pressure of the regulated air supply and press **enter**.

6.2 Internal Vacuum Sensor

The internal vacuum sensor is internally connected to the second vacuum pump and the **VACUUM 2** quick-connect. It is recommended you perform this calibration procedure after first performing the Internal Pressure Sensor calibration in the previous step. Following in this order you should already have the external air supply connected and set to the correct pressure.

Calibration of the internal vacuum is a two-step process that will require a compressed air supply plugged into the AIR IN quick connect and a vacuum line attached to VACUUM 2 quick connect. The vacuum line should be connected to the vacuum measuring instrument.

Set the Vacuum Zero Offset:

While in run mode select the vacuum display by pressing the **vacuum** key. Ensure Vacuum Pump #2 is **off**. If not select Vacuum Pump #2 using the **vacuum** key and then press the **vac on/off** key. Once the vacuum pump has been turned off bleed all the vacuum pressure out of the system through the hose attached to the Vacuum 2 quick-connect.

1. Enter the Calibration Menu and navigate to Calibration Menu #04

04	Internal Vacuum Calibration		
>Calibrate Zero	0.0 mV		Saved
Calibrate Span	-75 kPa		Saved

2. To perform a zero vacuum calibration select the 'Calibrate Zero' option using the **cursor** keys and press **enter**. The control case will automatically read the internal vacuum sensor and store it as the zero offset. This value cannot be manually modified.

Setting of the Vacuum Span:

3. Exit the Calibration Menu and navigate to Setup Menu #14. Set vacuum pump #2 control mode to manual 100% duty cycle.
4. Exit the Setup Menu and press the **vacuum** key to navigate to the Vacuum & Pressure Sensors screen.
5. Press the **vacuum** key again to move the small cursor to select vacuum pump #2 and press the **vac on/off** key to turn on vacuum pump 2.
6. Enter the Calibration Menu and navigate back to Calibration Menu #04.
7. Use the **cursor** keys to select the 'Calibrate Span' option. Adjust the displayed vacuum using the **option** keys so that the displayed value matches that shown on the vacuum measuring device connected via the vacuum 2 quick connect and vacuum hose.
8. Press **enter** to complete the vacuum span calibration.
9. Exit the Calibration Menu and follow steps 5&6 above to turn off vacuum pump #2.
10. You may also wish to repeat step 4 above and return the vacuum pump control mode to its previous state.

6.3 External Vacuum Sensor Inputs

The two external vacuum/pressure transducer inputs consist of identical loop powered 4-20mA inputs. The calibration procedure requires that you use a 4-20mA loop signal generator to simulate a calibrated 4mA and 20mA signal levels. The calibration procedure is the same for both inputs. The example here uses Vacuum 1 Calibration and its associated Calibration Menu #06. To calibrate Vacuum 2 input repeat the steps below using the transducer socket input Vacuum 2 and Calibration Menu #07.

NOTE: Plugging an externally powered 4-20mA signal source into the transducer input sockets may cause damage to the hardware.

1. Plug the 4-20mA sink source into the transducer input socket labelled Vacuum 1. Set the signal generator to 4mA
2. Enter the Calibration Menus and navigate to Calibration Menu #06

06	Vacuum 1 Calibration	
>Calibrate 4mA		+0.0% OK
Calibrate 20mA		+0.0% OK

3. Use the **cursor** keys to select 'Calibrate 4mA' and press the **enter** key. The control case automatically takes a reading and stores this to memory.
4. Next change the signal generator to output 20mA.
5. Use the **cursor** keys to select 'Calibrate 20mA' and press the **enter** key again.

7. POWER OUTPUT LEVELS AND THE VACUUM PUMPS

The heater outputs are provided to output power to heater blankets, heat lamps and potentially any other sort of resistive device within the operating specifications of the control case. The outputs are able to be driven in either phase fired or burst fired mode depending on how the device is configured and testing requires that both modes are checked separately.

7.1 Heater Outputs

There are no adjustments on the heater outputs so therefore there is no calibration procedure. However the output drive levels must be checked at several power levels.

The drive mode will automatically change from phase to burst at a preset level determined by Calibration Menu #08. The changeover point is generally set between 0 and 20%. At or above this threshold the outputs will always drive in burst mode and below this threshold the outputs will always be driven in phase mode.

Navigate to Calibration Menu #08 and set the phase / burst change point to 20%

08	Phase/Burst Threshold	
>Change at	20 %	Saved

Set all the heater outputs to **Manual** control in Setup Menu #16.

16	Zone Output Control	
>Zone 1	Manual	Saved
Zone 2	Manual	Saved
Zone 3	Manual	Saved

Connect a mains voltage 100W lamp to the outputs.

Set the power level of the outputs to the required levels in Setup Menu #17.

17	Zone Manual Output Settings	
>Zone 1 Power	10%	Saved
Zone 2 Power	10%	Saved
Zone 3 Power	10%	Saved

Follow the table below to confirm the operation of all three outputs.

Power level	Phase / Burst	Action to check	Power LED
0%	-	Lamp is off	Off
8 %	Phase	Lamp is barely turned on	On with low intensity
25%	Burst	Lamp flashes ~25% duty cycle	25% flash
50%	Burst	Lamp flashes ~50% duty cycle	50% flash
100%	Burst	Mains voltage on lamp constantly	On

7.2 Internal Vacuum Pumps

There are two vacuum pumps in the HBC-4301A. Each can be configured independently to run and a fixed rate or via feedback from one of the vacuum sensors to a fixed vacuum level. Neither of the vacuum pumps can be calibrated but they must be checked for the ability to generate a vacuum at a specific leak rates.

Check the Maximum Vacuum Pumping Rate

In order to test the operation of the vacuum pumps the first test is to check the maximum pumping rate of each vacuum pump. The examples given here are for Vacuum Pump #1 however the method for testing Vacuum Pump #2 is exactly the same using the Vacuum 2 quick connect and Vacuum 2 sensor input.

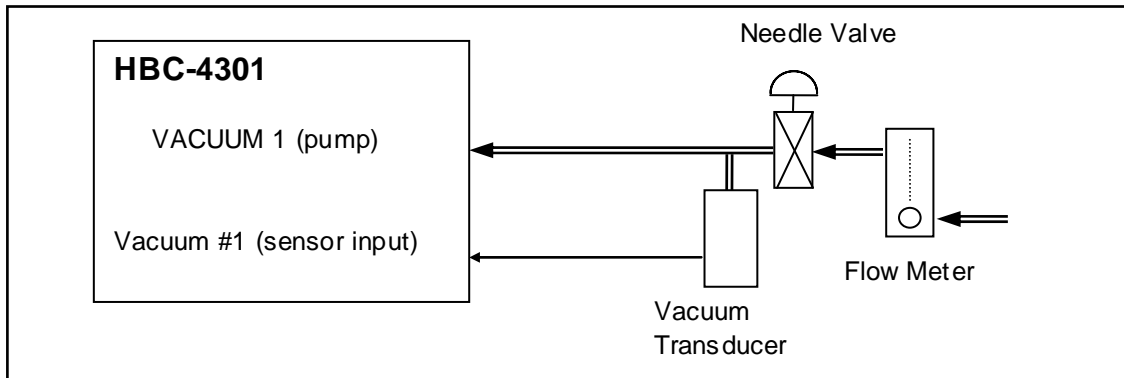

Figure 5: Vacuum Pump 1 Pumping Rate Test

1. Connect a vacuum hose to VACUUM 1 quick-connect. At the remote end of the hose, connect the following items as show in the diagram below –

Vacuum transducer, -1 to 0 Atm., 4-20mA loop powered output.

Needle valve

Flow meter, 0 to 5 l/min

2. Adjust the air supply pressure to 500 kPa and connect it to the air supply quick connect.
3. Enter the Setup Menu and navigate to Setup Menu #13. Set Vacuum Pump 1 to manual mode, 100% duty cycle. Press **enter** to store these values and **run** and return to run mode.
4. Press the **vacuum** key to show the Vacuum & Pressure status screen and use the **vacuum** and **vac on/off** keys to **turn on vacuum pump #1**.

It should be possible to achieve a vacuum level of -85kPa using Vacuum Pump #1 with a supply pressure of 500kPa and the needle valve closed. As the needle valve is opened, and the leak rate increased, the vacuum should drop in accordance with the graph in Figure 6 below.

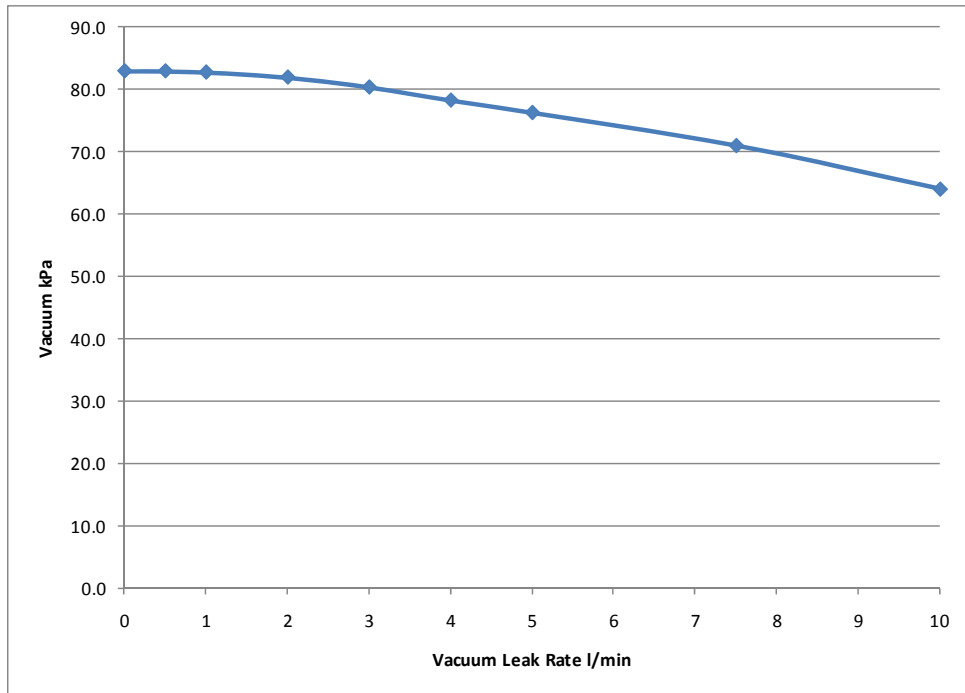

Figure 6: Vacuum Level at Specific Leak Rates

If it is not possible to achieve the level of vacuum shown check the filter fitted into the vacuum pump, or replace the pump.

Check the Automatic Vacuum Control

1. Enter the Setup Menu and navigate to Setup Menu #13. Set Vacuum Pump 1 to automatic mode, auto level -65kPa and control external #1. Press **enter** to store these values and **run** to return to run mode.
2. Press the vacuum key to show the Vacuum & Pressure status screen and use the **vacuum** and **vac on/off** keys to turn on vacuum pump 1.
3. Release the needle valve as shown in figure 5 to allow between 0.5 and 1.0 l/min vacuum flow.

During a 1 minute test check that the vacuum level is controlled at the rate of -65kPa. On completion try increasing and decreasing the leak rate from 0.1L/min up to 2L/min to confirm that the control case is capable of responding to changes in conditions.

8. SAFETY CHECKS

8.1 Earth Leak Detectors (Residual Current Detectors)

The HBC-4301A has been designed to protect the operator from electric shock by using a separate Residual Current Detector (RCD) on each heater circuit. The RCD also doubles as the power on / off switch for the control case outputs.

Turning on the **HEATER OUTPUT #1** RCD (labelled **MASTER**) also turns on the power supply for the electronics in the HBC-4301A.

There are no serviceable components in the RCD but they should be checked as part of the calibration process. Faulty RCD units can be replaced

1. Connect the power supply lead to the HBC-4301A control case.
2. Connect the power supply lead to the wall outlet socket.
3. Turn on all three-power switches (RCD's).
4. One at a time, press the TEST buttons on the edge of the RCD's.
5. The RCD should be seen to switch off.
6. Use an external RCD test instrument to check that the RCD's will switch off at <30mA and within 30mS

8.2 Earth Socket

The **EARTH** socket is wired to the mains supply power inlet socket using 1.5mm² cable. Measure the resistance between the **EARTH** socket and the earth pin of the mains supply inlet socket. It should be <0.3Ω. All other exposed metal parts of the cabinet should also be measured to be <0.3Ω.to the earth pin.

NOTE: To effectively measure the resistance of the **EARTH** connector a milliohm meter must be used. A common digital multimeter is not capable of accurately measuring 0.1Ω or passing a high test current.

8.2 Other Safety Issues

To complete the calibration and safety check the physical condition of the instrument should be assessed. This will require the control panel to be hinged up. Turn the power off and unplug the mains supply connector from the control panel.

Items to check include (but are not limited to) –

- Cable ties on any wires connected to mains supply voltage connectors
- Earth cables are all securely terminated
- There are no wires pinched by the hinged components
- The insulation film under the HBC4300-3 PCB is installed

Also check

- LK1 link on the HBC4300-1 PCB is off
- LK3 link on the HBC4300-1 PCB is off
- The calibration sticker has the correct calibration date

9. QUALITY CONTROL REPORT

The value of the calibration and safety check described in this document is distinctly reduced if a detailed full report is not kept. The report must follow a recognised quality system such as ISO9001: 2000.

An example of such a report is included in Appendix A in this manual for guidance purposes only.

Information Screen

Additional information on the calibration parameters can be obtained from the information screen. This screen is shown when the **zone Power** and the **enter** keys are pressed and held for 1 second.

Use the **function** keys to scroll up and down through the information.

APPENDIX A. HBC-4301A CALIBRATION CHECK LIST

Novatech Controls - HBC-4301A Checking Procedure

Hot Bonding Controller

Supplied to:		Date	
EPROM ver.		Serial No.	
PC software ver.		Order No.	

Visual check

Paint quality	
Scratches on anodised parts	
Beeper link off	

Cable ties	
Ferrites x2	
Earth straps	
Insulating film under power PCB	

Voltages

Power supply 5VDC	
Power supply +12VDC	
Power supply -12VDC	
TC Reference (12.3mV +/- 0.3)	
Reference #1 (53.6mV +/- 2.0)	
Reference #2 (481mV +/- 10)	

Calibration

Cold-start	
Enter date/time	
Enter reference voltages	

Accuracy (after calibration)

Temperature checked at ...	5	20	100	150	200	290
(+/- 1 °C)						

Measured ambient Temp		°C			
CJ temperature		°C	O/S set to-		+/- 4
CJ BU temperature		°C	O/S set to-		+/- 4
Case temperature		°C	O/S set to-		+/- 4
H/S temperature		°C	O/S set to-		+/- 6
Ext vac transducer #1	Zero	Span	4.5mA test	19mA test	
88 & 8 kPa, +/- 5					
Ext vac transducer #2	Zero	Span	4.5mA test	19mA test	
88 & 8 kPa, +/- 5					
Int. pressure transducers	O/S	Span	Zero test	(0 +/- 20)	Span test (500+/- 20)
Int. vacuum transducers	O/S	Span	Zero test	(0 +/- 3)	Span test (88 +/- 3)

Operation

Power output phase test, min 8%, 20 & 21%		
Power output burst test, 20 & 21%, max 100%		
High current test, 10A on each zone		
RCD trip, test button		
Computer power socket test		
Vac pump #2 manual control, leak rate 2 l/min	100%-	50%-
Vac pump #1, leak rate 2 l/min	100%-	

Additional Checks

Temperature cycle run	

Final check

EPROM version	
EPROM date	
Serial number sticker	
Calibration sticker	

Signed	
Date	