

## Carbon Analyser

### Model 1634



August 2007



# CONTENTS

1. SPECIFICATIONS
2. DESCRIPTION
3. INSTALLATION & COMMISSIONING
4. OPERATORS FUNCTIONS - ALARMS
5. SETTING UP THE ANALYSER
6. MAINTENANCE

## APPENDIX

1. CONSTITUENT VALUES FOR VARIOUS FUELS
2. PROBE EMF TABLES
3. LOG OXYGEN SCALE
4. SAMPLE LOG PRINT OUT
5. CIRCUIT SCHEMATIC
6. MODBUS™ REGISTER MAP AND APPLICATION NOTES

**Note: This manual includes software modifications up to Version 4.04, August, 2003**

© Copyright NOVATECH CONTROLS PTY. LTD. - 1996 - 2007

This manual is part of the product sold by Novatech Controls Pty. Ltd. ("Novatech Controls") and is provided to the customer subject to Novatech Controls' conditions of sale, a copy of which is set out herein. Novatech Controls' liability for the product including the contents of this manual is as set out in the conditions of sale.

All maintenance and service of the product should be carried out by Novatech Controls' authorised dealers.

This manual is intended only to assist the reader in the use of the products. This manual is provided in good faith but Novatech Controls does not warrant or represent that the contents of this manual are correct or accurate. It is the responsibility of the owner of the product to ensure users take care in familiarising themselves in the use, operation and performance of the product.

The product, including this manual and products for use with it, are subject to continuous developments and improvement by Novatech Controls. All information of a technical nature and particulars of the product and its use (including the information in this manual) may be changed by Novatech Controls at any time without notice and without incurring any obligation. A list of details of any amendments or revisions to this manual can be obtained upon request from Novatech Controls. Novatech Controls welcome comments and suggestions relating to the product including this manual.

Neither the whole nor any part of the information contained in, or the product described in, this manual may be adapted or reproduced in any material form except with the prior written approval of Novatech Controls Pty. Ltd.

All correspondence should be addressed to:

Technical Enquiries  
Novatech Controls Pty Ltd  
309 Reserve Road  
Cheltenham Victoria 3192  
Australia

Phone: Melbourne +61 3 9585 2833  
Fax: Melbourne +61 3 9585 2844  
Website: [www.novatech.com.au](http://www.novatech.com.au)

# USING THIS MANUAL

The Novatech 1634 Carbon Analyser/Transmitter has a variety of user-selectable functions.

They are simple to use because each selection is menu driven. For options you are not sure about; read the manual on that particular item.

Please read the 'Installation' section before connecting power to the analyser.

# SPECIFICATIONS

# 1

- 1.1 MODEL 1634 CARBON ANALYSER FOR TWO PROBES
- 1.2 SERIES 1230 CARBON PROBES
- 1.3 PURGE SYSTEM
- 1.4 PROBE PURGE PRESSURE SWITCH

## 1.1 MODEL 1634 CARBON ANALYSER FOR TWO OXYGEN PROBES

### DESCRIPTION

The Novatech model 1634 carbon analyser/transmitter provides in-situ measurement for two oxygen probes in furnaces and gas generators with temperatures up to 1400°C. The analyser provides local indication of carbon percentage and oxygen plus thirteen other selectable variables.

One or two probes in one process can be controlled from one analyser providing an average and/or individual probe signals. Two linearised and isolated 4 to 20 mA output signals are provided. Alarms are displayed at the analyser and relay contacts activate remote alarm devices. The analyser, which is available for unheated zirconia oxygen, provides automatic probe filter purging. The electronics self-calibrates all inputs every minute.

The 1634 has a keyboard for selecting the output range, thermocouple type, etc., as well as maintenance and commissioning functions. The instrument is microprocessor based and all adjustments are made using the keyboard.

In addition to its use as a local indicator of carbon potential in a furnace, the 1634 may be used in conjunction with an IBM personal computer running the 'Furnace Master' program. This allows complete automation of a furnace from pre-programmed recipes, with a batch report at the end of the job,

- Calculates carbon potential for propane, methane or nitrogen/methanol generators
- Linear 4-20mA output of % carbon
- Interfaces to an IBM PC for completely automatic control
- 26 different alarm conditions that warn the operator of generator/furnace, probe or analyser problems
- Automatic adjustment free calibration
- Built in safety features
- Isolated RS 232-C / RS 485 printer/computer interface
- Simple to install

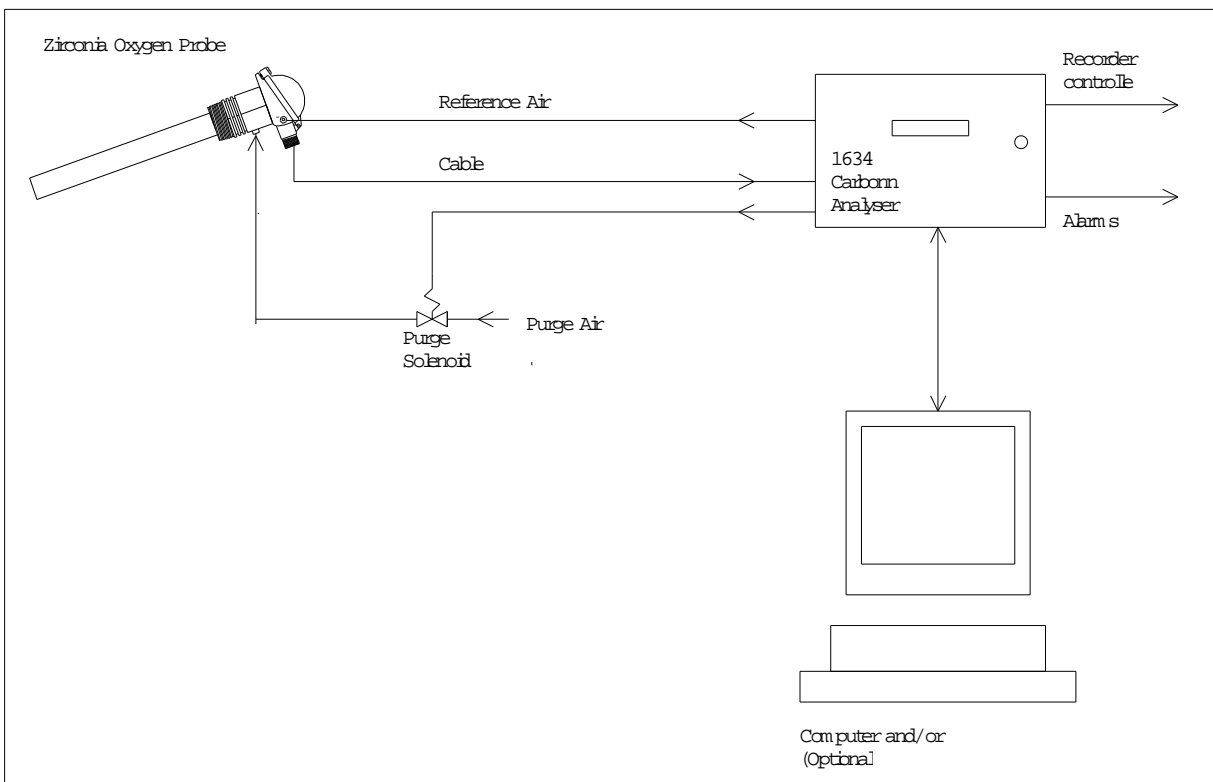

## SPECIFICATIONS

### Inputs

- Zirconia oxygen probe, unheated
- Furnace or auxiliary thermocouple, field selectable as type T, J, K, R, S, N
- Purge pressure switch
- Remote alarm accept

### Outputs

- Two linearised 4 to 20 mA DC outputs, max. load 1000Ω
- Common alarm relay
- Three other alarm relays with selectable functions

### Computer

- Isolated RS 232-C or RS 485 for connection of a computer terminal or printer for diagnostics of the analyser, probe, or furnace. This connection will be suitable for network connection to computers, DCSs or PLCs

### Range of Output 1

Field selectable from the following:

<i>Output Selection</i>	<i>Range</i>
Linear, Probe 1	0 to 1.5% carbon
Linear, Probe 1 and 2 averaged (If 2 probes are used)	0 to 1.5% carbon

### Range of Output 2

Field selectable from the following:

<i>Output</i>	<i>Zero Range</i>	<i>Span Range</i>
Carbon, Probe 2 **		
Probe EMF, probe 1	0 to 1200 mV in 100 mV steps	100 to 1300 mV in 100 mV steps
Probe EMF, probe 2 **	0 to 1200 mV in 100 mV steps	100 to 1300 mV in 100 mV steps
Probe temperature, probe 1	0-1300 °C in 100 °C steps	100-1400 °C in 100 °C steps
Probe temperature, probe 2 **	0-1300 °C in 100 °C steps	100-1400 °C in 100 °C steps
Log Oxygen	0.1% O <sub>2</sub> Fixed	20% O <sub>2</sub> Fixed
Reducing Oxygen	10 <sup>-1</sup> to 10 <sup>-25</sup> % oxygen in one decade steps, non-overlapping Min span two decades	10 <sup>-1</sup> to 10 <sup>-25</sup> % oxygen in one decade steps.

### Range of Indication, Upper Line

Probe 1, Carbon

- 0.000 to 1.700 % Carbon (Calculation accuracy 0.02% between 0.2 and 1.2 % carbon)

### **Indication Choice, Lower Line**

Any or all of the following can be selected for lower line display:

- Carbon, probe #2, 0.000 to 1.700
- Carbon, average probe #1 and #2, 0.000 to 1.700
- Oxygen, probe #1
- Oxygen, probe #2 \*\*
- Probe EMF #1
- Probe EMF #2 \*\*
- Probe temperature #1
- Probe temperature #2 \*\*, Auxiliary Temperature
- Date - time
- Run Hours since last service
- Date of last service
- Probe 1 oxygen
- Probe 2 oxygen \*\*
- Probe 1 EMF
- Probe 2 EMF \*\*
- Probe Impedance, Probe #1
- Probe Impedance, Probe #2 \*\*
- Ambient Temperature
- Ambient Relative Humidity

### **Accuracy**

- 0.02% carbon within the range of 0.2 to 1.2%,
- with a repeatability of 0.001% carbon.

### **Relay Contacts**

- 0.5A 24 VAC, 1A 36 VDC

### **Environmental Rating**

- Operating Temperature: -25 to 55°C (-15 to 130°F)
- Relative Humidity: 5 to 95% (non-condensing)
- Vibration: 10 to 150Hz (2g peak)

### **Power Requirements**

- 240 or 110V, 50/60 Hz, 105 VA (heated probe)
- 240 or 110V, 50/60 Hz, 5 VA (unheated probe)

### **Weight**

- Analyser, 3.75 kg (10 lbs.)

### **Dimensions**

- 280mm (11") W x 180mm (7") H x 95mm (3.75") D

### **Degree of Protection**

- IP65 without reference air pump
- IP54 with reference air pump

### **Mounting**

- Suitable for wall or surface mounting.



## 1.2 SERIES 1230 OXYGEN PROBES

### FEATURES

- More consistent and reliable products from heat treating furnaces
- Fuel savings and pollution control in furnaces, boilers and kilns
- Low cost
- Simple to install

### DESCRIPTION

Novatech series 1230 probes provide in-situ measurement of the oxygen and carbon level in furnaces, boilers and kilns. In atmosphere control of metal and ceramic heat treatment processes, series 1230 probes provide improved quality control. Series 1230 probes allow major fuel savings in combustion control applications. The selection of probe model depends on the temperature and the constituents of the gas to be measured (Refer to Section 1.5, Specifications).

Novatech series 1230 oxygen probes employ state-of-the-art zirconia sensors and advanced materials, which provide the following benefits:

- Improved control due to fast response time to typically less than four seconds
- Cost-efficient design provides improved reliability
- Longer-life probe due to greater resistance to corrosion from sulphur and zinc contaminants in furnace gases
- Low cost allows maintenance by replacement
- Reduced probe breakage due to greater resistance to thermal shock and mechanical damage during installation and start-up

Series 1230 probes are simple to install and maintain. Models 1232 and 1233 provide direct measurement of carbon level. Probes may be used with Novatech carbon analysers and some model analysers from other manufacturers.

All Novatech oxygen probe are designed and manufactured to exacting standards of performance and reliability. Series 1230 probe are the result of extensive research and development by Novatech, industry and government agencies. Novatech Controls provides application and after sales support for oxygen probes, sensors and analysers, world-wide.

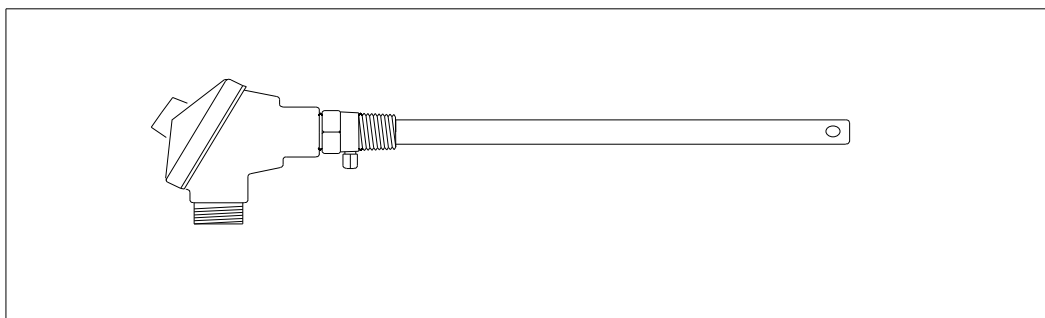

**Model 1232 Unheated Oxygen Probe**

## STANDARD PROBE 'U' LENGTHS

### 1232

250 mm  
500 mm  
750 mm  
1000 mm

### 1233

457 mm  
609 mm  
914 mm  
1219 mm

### Ordering Information

1. Probe insertion length (from process end of mounting thread to probe sensing tip).
2. Mounting thread (process connection), BSP or NPT (for size of thread refer to specifications).
3. Lagging extension length, if required.
4. If model 1232 probe, state preferred thermocouple type (refer to specifications).
5. Probe cable (run distance between the probe and the analyser)
6. Lagging extension length, if required.

Ask your local Novatech Distributor for assistance in ordering.

## CARBON PROBE SPECIFICATIONS

<b>MODEL</b>	<b>1232</b>
<b>Application</b>	Furnace temperatures above 700°C( 1290°F) with no contaminants. eg. natural gas, light oils
<b>Temperature Range</b>	700 to 1400°C
<b>Length</b>	500 to 1500 mm
<b>Process Connection</b>	3/4" BSP or NPT
<b>Electrical Connection</b>	Weather-proof plug-in connector or optional screw terminals. The plug connector is supplied with the cable.
<b>Cable</b>	Order a specific length with the analyser.
<b>Heater</b>	No
<b>Auxiliary Gas Thermocouple</b>	R or S, integral
<b>Response Time</b>	Typically < 1 sec
<b>Head Temperature</b>	-25 to 100°C (-15 to 210°F) with weatherproof connector -25 to 150°C (-15 to 300°F) with screw terminals
<b>Reference Gas</b>	Ambient air 50 cc/min approx. Pump supplied with analyser
<b>Ref Air Connection</b>	Integral air line in probe cable or 1/4" tube for external airline.
<b>Purge Gas Connection</b>	1/16" NPT female 1/16" NPT female
<b>Weight</b>	1 kg plus 100g / 100 mm length

### Notes:

1. Please contact factory for corrosives atmospheres. We can provide test materials to try in your atmosphere.

## OXYGEN PROBE MODEL SELECTION GUIDE

### *Unheated probes for clean gases-temperature range 700-1400°C.*

1232	-	U Length	-	Outer Sheath	-	Internal Thermocouple	-	Mounting Thread	
Basic model	3.	500mm		1.	253 MA-max 1200°C	1.	Nil *(2)	1.	3/4" BSP fixed
	4.	750mm		2.	Aluminous Porcelain	4.	Type R max 1400°C	2.	3/4" NPT fixed
	5.	1000mm			max 1300°C Horizontal				
	6.	1160mm			max 1400°C Vertical				
	7.	Special 140mm min		3.	High Purity Alumina				
					max 1300°C Horizontal				
					max 1400°C Vertical				
				4.	446 SS max 1000°C				

- \*Note:
- (1) A standard oxygen probe for carburising furnaces, has a 253 MA sheath.
  - (2) For applications up to 1500°C it may be more economical to use a separate type "K" or "N" thermocouple than the internal "R" thermocouple. It is important that a separate thermocouple senses the same temperatures as the Oxygen probe tip.

### *Unheated probes for contaminated gases-temperature range 700-1200°C.*

1233	-	U Length	-	Internal Thermocouple	-	Mounting Thread	
Basic model	2.	457mm		1.	Type R max 1400°C	1.	1" BSP
	3.	610mm				2.	1" NPT
	4.	914mm					
	5.	1220mm					

## 1.3 PROBE FILTER PURGE

Novatech probes and analysers provide a ready method of connecting on-line and automatic probe filter purge facility.

Dirty furnace gas applications often require the back purge facility to keep a probe sensor free from blockage. The purge solenoid valve can be operated manually or automatically from a 1634 analyser.

The external components required for automatic / manual purging are:

- A mains voltage (240 or 110 VAC) purge solenoid valve
- A Pressure regulator, 0 to 100 kPa (0 to 15 PSI)
- A purge pressure switch, 0 to 35 kPa (0 to 5 psi), to test for filter blockage.

The user should supply:

- A 100 kPa (15 psi) clean and dry instrument air supply when filter purging is required.

## 1.4 FILTER PURGE PRESSURE SWITCH

To automatically sense a blocked probe filter, a pressure sensor should be connected to the 'purge' line to the probe 'cal' port. It should be adjusted so that it energises just above the purge pressure with a new or clean filter installed. The switch contacts should be connected to terminals 12 & 13 (PURGE FL SWITCH).

If the filter is still blocked or partly blocked after an auto purge cycle, the pressure switch will energise and cause a 'Probe Filter Blocked' alarm.

The pressure switch should have an adjustable range of 0 to 35 kPa (0 to 5 psi).

# 2 DESCRIPTION

## SECTION NUMBER

- 2.1 THE ZIRCONIA SENSOR
- 2.2 THE CARBON PROBE
- 2.3 THE ANALYSER / CONTROLLER
- 2.4 ALARMS
- 2.5 APPLICATIONS WHERE SENSING POINT  
IS NOT AT ATMOSPHERIC PRESSURE
- 2.6 PROBE IMPEDANCE
- 2.7 AUTO CALIBRATION—ELECTRONICS
- 2.8 AUTO PURGE
- 2.9 RS 485 NETWORK (MODBUS™) AND 232-C PORT
- 2.10 AUXILIARY TEMPERATURE THERMOCOUPLE
- 2.11 WATCHDOG TIMER
- 2.12 BACK UP BATTERY

## DESCRIPTION

### 2.1 THE ZIRCONIA SENSOR

The analyser input is provided from a solid electrolyte oxygen probe which contains a zirconia element and thermocouple. The probe is designed to be inserted into a furnace atmosphere. Sampling lines and filters are not required for in-situ probes. A reference air pump is provided in the 1634 oxygen analyser.

The internal construction of a probe is shown as follows. The 1232 and 1233 unheated probes do not have a heater.

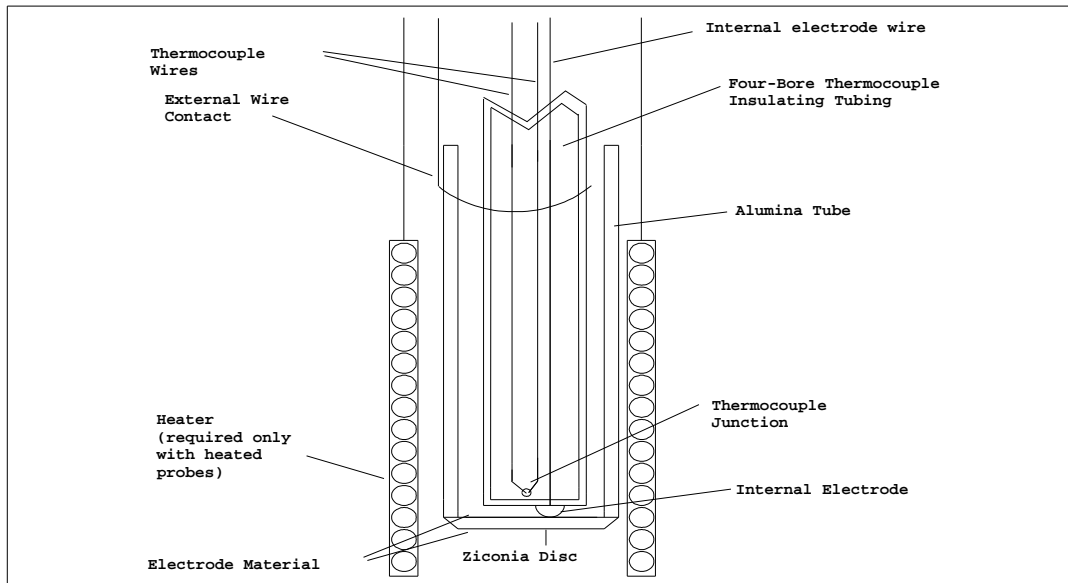

**Schematic View of a Sensor Assembly**

The zirconia element is sealed to the end of an alumina tube. The furnace must raise the temperature of the sensor to above 650 °C for the ionic activity to be sufficient for the zirconia to conduct.

Probes operating in a combustion environment above 650°C, when exposed to different oxygen partial pressures at the outside and inside of the sensor, will develop an EMF (E) which obeys the Nernst equation:

$$E \text{ (millivolts)} = \frac{RT}{4F} \log_e \left( \frac{(PO_2) \text{ INSIDE}}{(PO_2) \text{ OUTSIDE}} \right)$$

Where T is the temperature (K) at the disc (>650°C), R is the gas constant, F is the Faraday constant and (PO<sub>2</sub>) INSIDE and (PO<sub>2</sub>) OUTSIDE are the oxygen partial pressures at the inner and outer electrodes, respectively, with the higher oxygen partial pressure electrode being positive.

If dry air at atmospheric pressure, (21 % oxygen) is used as a reference gas at the inner electrode, the following equations are obtained:

$$E \text{ (millivolts)} = 2.154 \times 10^{-2} T \log_e \frac{0.21}{(PO_2) \text{ OUTSIDE}}$$

Transposing this equation

$$(\%O_2) \text{ OUTSIDE (ATM)} = 0.21 \text{ EXP } \frac{-46.421E}{T}$$

The 1634 transmitter solves this equation which is valid above 650°C. The process maintains the sensor temperature at this level, from which it then calculates the carbon potential of the atmosphere.

## 2.2 THE CARBON PROBE

The probe assembly provides a means of exposing the sensor to the atmosphere to be measured with sensor, thermocouple and heater wires connected via the analyser lead. Reference air is fed via the plug for unheated. Connections are provided on probes a cleaning purge of air can be admitted via the 'CAL' entry. The outer sheath of probes can be metal or ceramic, depending on the application.

## 2.3 THE ANALYSER / CONTROLLER

The analyser will calculate the carbon level in a furnace, and can also be configured to control the furnace carbon level.

### 2.3.1 1634 ANALYSER

The 1634 analyser is designed to operate with either one or two zirconia probes in one process. If two probes are being used, the analyser can average the two carbon signals, alarm when there is a high difference, transmit and display the average and/or individual carbon signals.

The 1634 analyser is a transmitter with two 4 to 20 mA outputs. One output is % carbon, either one probe or the average of two probes if available. The second output can be selected as carbon from probe #2 (if available), auxiliary temperature, sensor 1 or 2 EMF, reducing oxygen, or a logarithmic oxygen range. Four alarm relays are provided. Refer to the sections 4.2 and 4.3 for more details.

The analyser solves the Nernst equation and will provide accurate oxygen and carbon measurements up to 1500°C (2730°F), although most probes are suitable only to 1400°C (2250°F). The percent carbon is calculated from the oxygen and the known gas specifications.

### 2.3.1 1634 CONTROLLER

Using set-up menu items 43 to 48, the 1634 can also be configured to control the furnace atmosphere.

The menu items are -	43	'Controller'	Selection of controller operation mode.
		Options- 'No Control'	
		'ON/OFF'	Simple on/off solenoid
		'Proportional ON/OFF'	Time proportioned solenoid
		'Proportional 4-20mA'	4-20mA modulation motor drive valve
		'Proportional UP/DOWN'	Up/down motor drive valve
	44	'Carbon Set Point'	The carbon potential required in the furnace.
	45	'Carbon Prop Band'	Adjustment of the control sensitivity.
	46	'Carbon Dead Band'	Adjustment of the no control action band.
	47	'Carbon Reset Action'	Adjustment of the automatic long term adjustment.
	48	'Carbon Cycle Time'	Proportional ON/OFF and UP/DOWN cycle time

Select the type of valve to be used, and then select the control mode to be used.

*Simple solenoid system-* A small bypass line around the main enrichment control valve on the furnace can be installed with an on/off solenoid. Select either 'ON/OFF' control ' or 'Proportional ON/OF' control. Connect the mains voltage solenoid to Cal1 Solenoid (terminals 43 & 44).

*Proportional Valve Control-* If a proportional valve is to be used, select the appropriate controller mode ('Proportional 4-20' or Proportional UP/DOWN) to drive the valve. 'Proportional 4-20mA' mode uses channel #2, 4-20mA output (terminals 27 & 28), and 'Proportional UP/DOWN' uses Cal1 Solenoid and Cal2 Solenoid outputs (terminals 43/44 and 45/46).

If a proportional control mode has been selected, also set the sensitivity of the control system with the proportional band in set-up item 45. The smaller the proportional band number, the larger the output valve adjustment reaction will be to an atmosphere change.

Set the 'Cycle Time' value in set-up 48 when using 'Proportional ON/OFF' or 'Proportional UP/DOWN' control modes to match the 1634 controller to the furnace. Keep the time as long as possible (maintaining smooth control) to reduce the wear on the control valve. The wear on a 4-20mA control valve or an up/down motor can be reduced by increasing the 'Dead Band'.

When the above menu items have been configured for the furnace, adjust the 'Set Point' in set-up 44 to the desired carbon level in the furnace. The 'Carbon Set Point' can be displayed on the lower line of the 1634 (see set-up 35 in section 5.5)

## **2.4 ALARMS**

Refer to OPERATOR FUNCTIONS Section 4 for details on alarm functions.

## **2.5 APPLICATIONS WHERE SENSING POINT IS NOT AT ATMOSPHERIC PRESSURE**

To apply the 1634 analyser to processes which have pressure at the point of measurement significantly above or below atmospheric pressure, a compensation must be applied. (Refer to Set-up Steps 36 and 37 in Section 5.5). If two probes are being used, they must be close to the same pressure.

## **2.6 PROBE IMPEDANCE**

The probe impedance is a basic measurement of the reliability of the oxygen reading. A probe with a high impedance reading will eventually produce erroneous signals. The analyser checks the probe impedance every 5 minutes and if the impedance is above the maximum level for a specific temperature then the impedance alarm will be activated. Typical probe impedance is 0.5 K $\Omega$  to 3 K $\Omega$  at 900° C.

## **2.7 AUTO CALIBRATION - ELECTRONICS**

The analyser input section is self calibrating. There are no adjustments. The analog to digital converter input stages are checked against a precision reference source and calibrated once every three seconds. Should the input electronics drift slightly then the drift will be automatically compensated for within the microprocessor. If a large error occurs due to an electronic fault then an 'ADC CAL FAIL' alarm will occur.

A one-off calibration procedure of the precision reference sources should never need to be repeated for the instrument life unless the instrument has been repaired. For a description of the calibration procedure, refer to 'Setting Up The Analyser' Section 5.5, items 7, 8 9 and 10.

The digital to analog converters or output section of the analyser are tested for accuracy every three seconds and if they are found to have an error then a 'ADC CAL FAIL' alarm will occur. The D/A sections are re-calibrated by pressing the 'AUTO CAL' button on the keyboard while in 'SET-UP' mode.

All output signals will drop to 0 mA for one second period. It is suggested that a D/A re-calibration be performed after the instrument has stabilised, approximately 30 minutes after first switching on and after Setting Up The Analyser Section 5.5, items 6, 7, 8 and 9 have been completed, and then annually.

## **2.8 AUTO PURGE**

In very 'sooty' furnaces, it is possible for the probe sensor to become blocked. An automatic purge cycle can be set up so that a short burst of air, maximum 100 kPa., will automatically back-flush and burn off the carbon from around the sensor on a timed basis. Refer to Set-up steps 38 to 42 in Section 5.5. A purge pressure switch will sense if there is insufficient flow to clear the probe during the purge cycle. In this case a 'PROBE FILTER' alarm will occur. The probe can be manually purged from the keyboard while in 'RUN' mode. The analyser output is not frozen during or after the pressing of this button.

If two probes are being used, two pressure regulators, two solenoids and two pressure switches (wired in series to terminals 12 & 13) should be used.

## **2.9 RS 485 NETWORK (MODBUS™) AND RS 232C PORT**

The serial port has two functions. -

- It can be configured to connect up to 31 analysers together on a MODBUS™ RS485 network.

Each individual analyser can be interrogated by a computer or PLC. The values of oxygen, sensor EMF, sensor temperature, sensor impedance for both oxygen sensors (if two sensors are being used on one analyser) can be read over the network. The alarms status can also be checked over the network.

For the connection details, see Section 3.14 and Appendix 6.

- It can be used to log the analyser readings by connecting the analyser to a printer, a data logger, or any computer using an RS232-C com port.

When it is to be used to log the analyser readings, use set-up step 82 to selected the items to be sent to the data logger. The log period may be selected in set-up step 83, and the baud rate may be set in set-up step 84. Alarms, including the time they occurred, will be transmitted to the printer and computer whenever they are first initiated, accepted and cleared. The protocol for the serial port is eight data bits, one stop bit, no parity.



## **2.10 AUXILIARY TEMPERATURE THERMOCOUPLE**

An auxiliary thermocouple can also be connected (if only one probe is being used) to display or transmit an additional temperature if required.

## **2.11 WATCHDOG TIMER**

The watchdog timer is started if the microprocessor fails to pulse it within any one second period, (ie. fails to run its normal program). The microprocessor will then be reset continuously until normal operation is resumed. Reset cycles are displayed by the POWER light on the keyboard. A steady 'ON' light indicates normal operation. If the program has not resumed normal operation after two attempts to reset, the common alarm relay will be activated. The reset function will continue repeatedly after the alarm. If a successful reset is achieved, the alarm will be cancelled and the analyser will continue to run normally.

## **2.12 BACK-UP BATTERY**

The transmitter's RAM and real-time clock are backed up by a lithium battery in the event of power failure. All set-up variables are saved and the clock is kept running for approximately ten years with the power off. The battery module should be replaced every 8 years. (It is the battery shaped device clipped in a socket labelled M1. This device also contains a serial number and must be purchased from Novatech Controls.



# INSTALLING & COMMISSIONING

# 3

## SECTION NUMBER

## INSTALLATION

- 3.1 MOUNTING THE ANALYSER
- 3.2 INSTALLING A CARBON PROBE
- 3.3 INSTALLING THE AUXILIARY THERMOCOUPLE
- 3.4 SHIELD CONNECTIONS
- 3.5 ELECTRICAL CONNECTIONS
- 3.6 CONNECTING A CARBON PROBE CABLE
- 3.7 CONNECTING THE AUXILIARY THERMOCOUPLE (OPTIONAL)
- 3.8 CONNECTING THE OUTPUT CHANNELS
- 3.9 CONNECTING THE ALARMS
- 3.10 CONNECTING THE AUTOMATIC PURGE SYSTEM
- 3.11 CONNECTING REFERENCE AIR
- 3.12 CONNECTING THE PRINTER
- 3.13 CONNECTING THE CONTROL VALVE / SOLENOID
- 3.14 CONNECTING THE ANALYSER TO A MODBUS™ NETWORK

## COMMISSIONING

- 3.15 CONNECTING POWER
- 3.16 COMMISSIONING - SET-UP MODE
- 3.17 COMMISSIONING - RUN MODE
- 3.18 CHECKING ALARMS
- 3.19 PROBE CALIBRATION
- 3.20 FILTER PURGE SET-UP PROCEDURE
- 3.21 SOOTING IN THE FURNACE

# INSTALLATION

## 3.1 MOUNTING THE ANALYSER

Surface mount the transmitter case on to a flat surface or bracket, using the four mounting brackets provided.

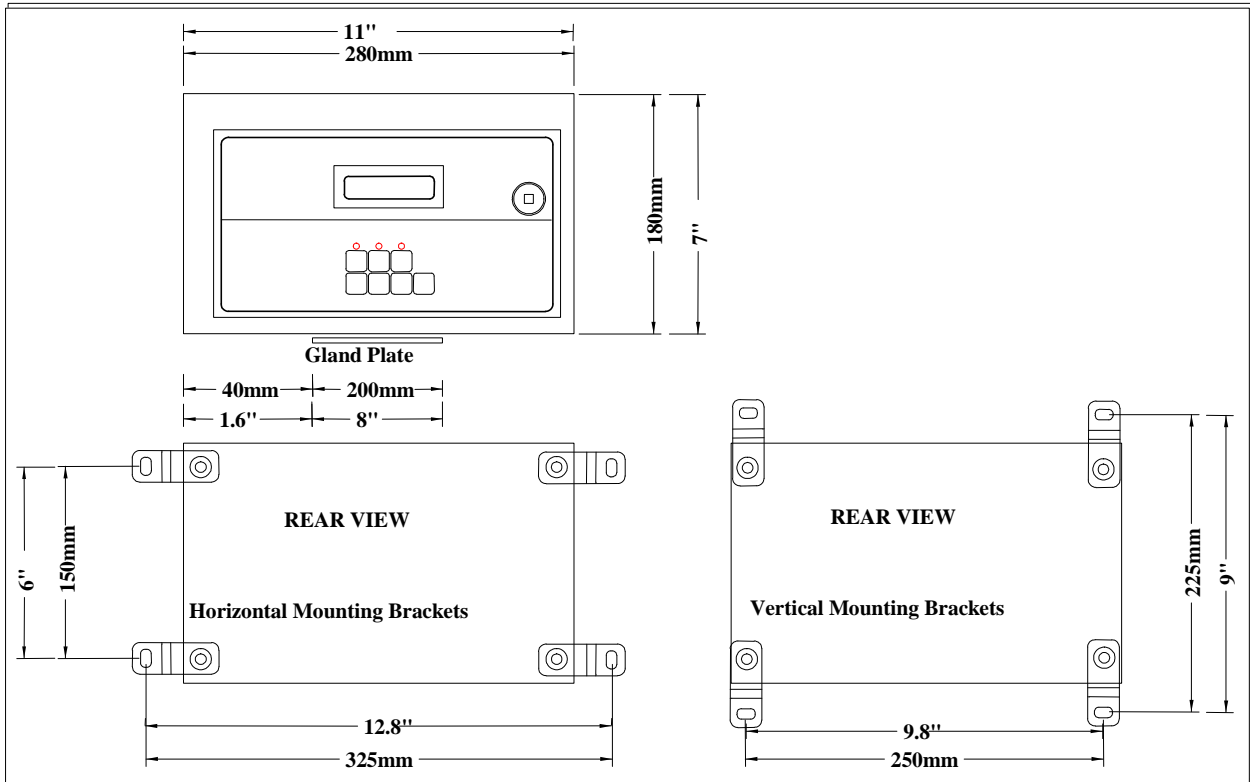

Case Mounting Dimensions

### 3.2 INSTALLING A CARBON PROBE

Weld a BSP or NPT socket to the flue in a suitable position for flue gas sensing. For the correct size of socket refer to probe data in Section 1. The closer to the source of combustion the smaller will be sensing lag time, allowing better control. Try to place the carbon probe in a position where it is sensing a representative gas in the furnace. (i.e. Not too close to the endo injection port).

Probes can be mounted at any angle

If installing a probe into a hot environment, slide the probe in slowly to avoid thermal shock to the internal ceramic parts. If the flue gas is 900°C, it should take approximately ten minutes to install a 500 mm. probe, moving it in about 20 mm. steps.

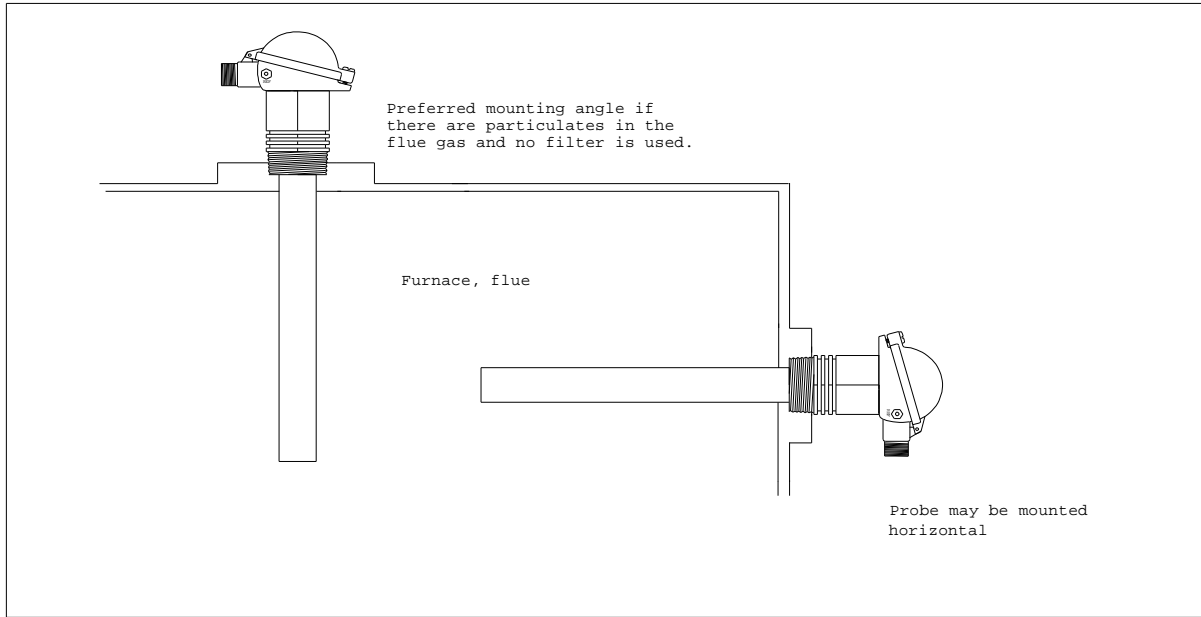

**Oxygen Probe Mounting**

#### CAUTION

It is important that there is no air in leakage near of the carbon sensing point, otherwise there will be a low carbon reading.

### 3.3 INSTALLING THE AUXILIARY THERMOCOUPLE

Weld a 1/2 inch BSP mounting socket to the flue within about 300 mm, and upstream of the oxygen probe. The thermocouple should be of similar length to the oxygen probe to prevent flue temperature distribution errors.

### 3.4 SHIELD CONNECTIONS

All external wiring to the 1634 analyser should be shielded. Do not connect shields at the field end. Simply clip off and insulate. An extra terminal strip may be required to connect all shields together. This should be supplied by the installer.

### 3.5 ELECTRICAL CONNECTIONS

All wiring should comply with local electrical codes. The printed circuit boards are fully floating above earth. All earth and shield connections should be connected to the earth stud on the LHS inside the case. Before connection of mains power check that the 115 / 230 volt power selector switch is set to the correct voltage.

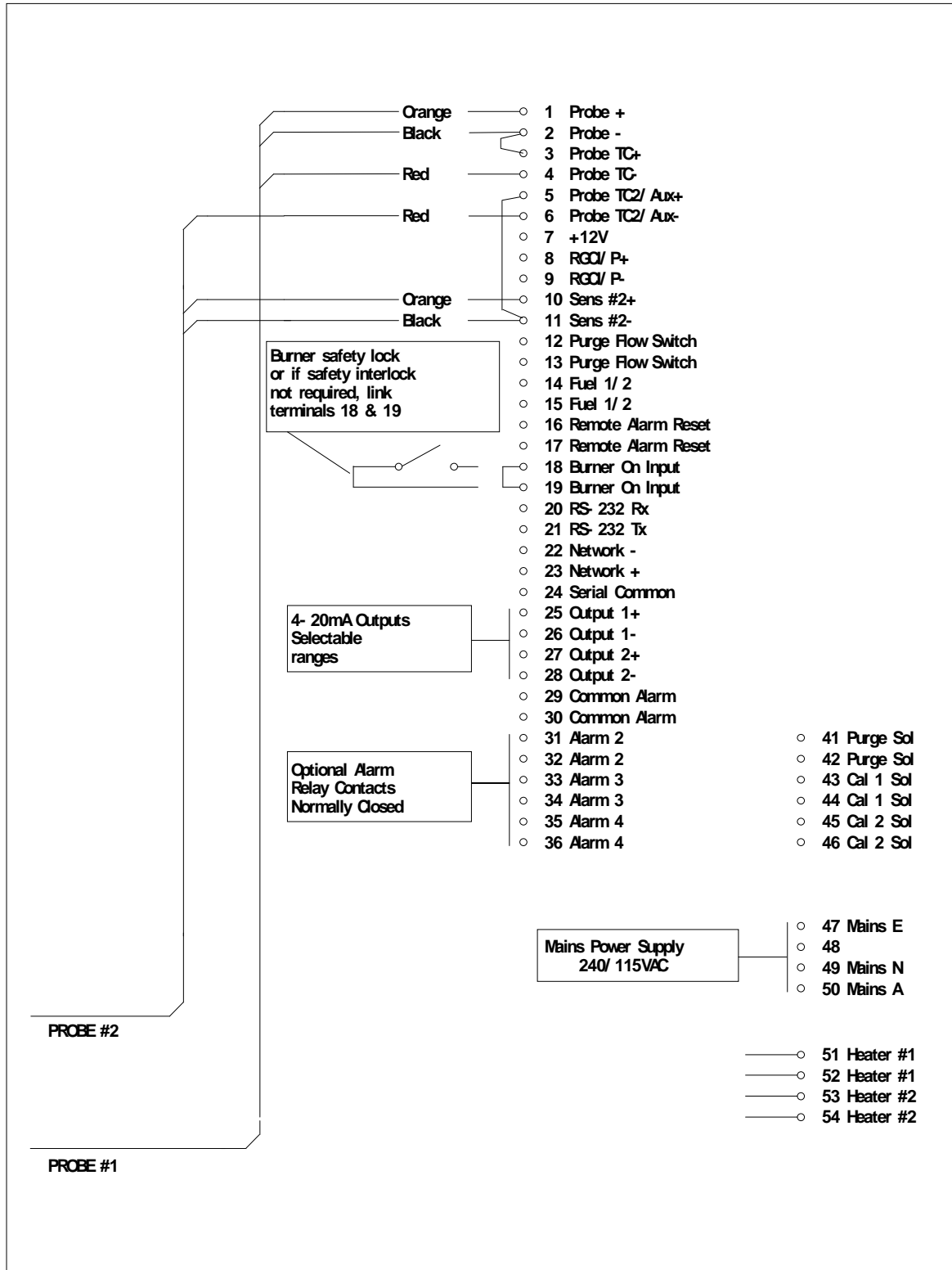

Connection Diagram for 1634 Analyser and one or two 1232 Unheated Sensors

### 3.6 CONNECTING THE CARBON PROBE CABLE

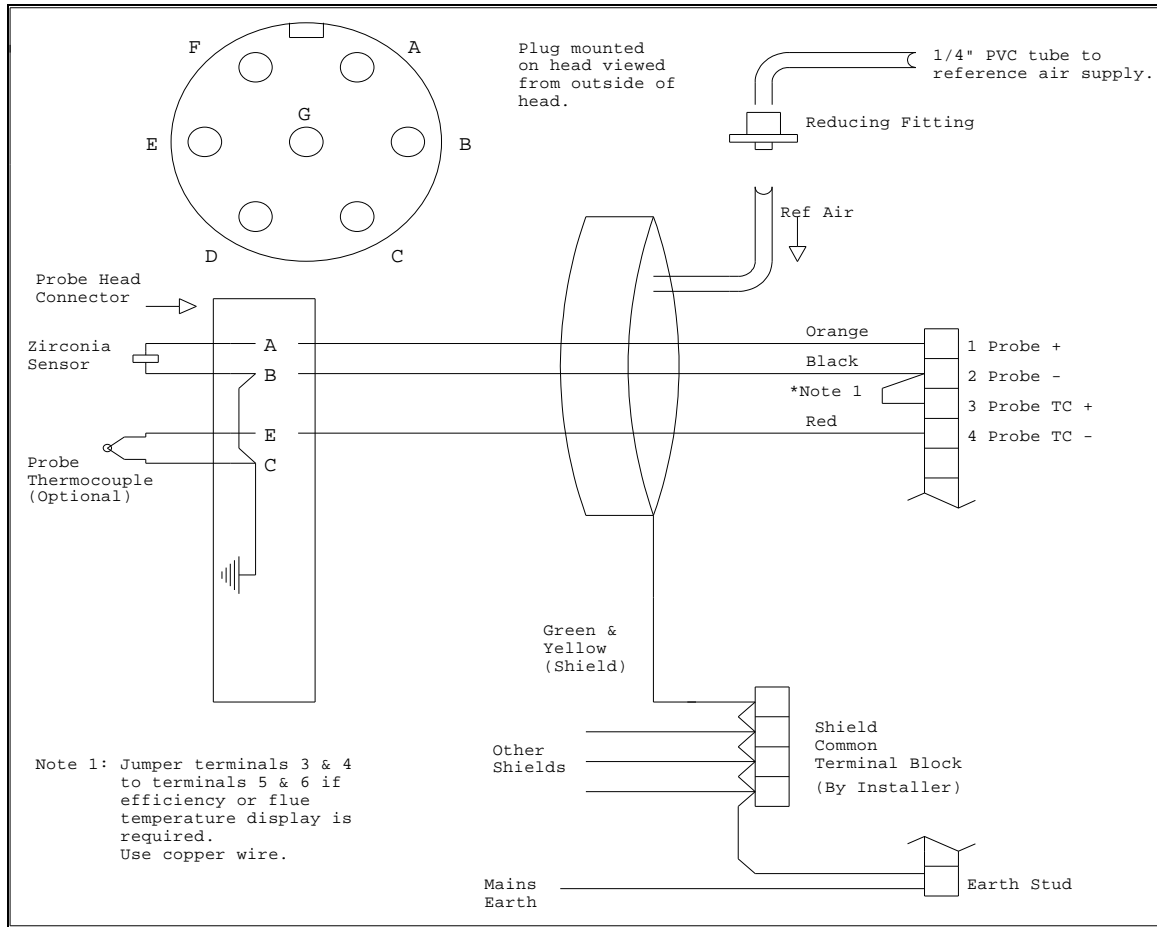

**Connection of Probe Cable for Unheated Probes Models 1232 and 1233.**

### 3.7 CONNECTING THE AUXILIARY THERMOCOUPLE (OPTIONAL)

For applications that require an additional temperature to be transmitted or displayed, a thermocouple can be connected to terminals 5 & 6. This is only possible if only one probe is being used. It can be any one of types T, J, K, R, S or N. It is optional.

### 3.8 CONNECTING THE OUTPUT CHANNELS

The two 4 to 20 mA DC output channels are capable of driving into a 1000Ω load. The channels are connected to terminals 25 & 26 for channel 1, and 26 & 27 for channel 2. For output selections and ranges see Section 5.5, set-ups 26 to 31.

### 3.9 CONNECTING THE ALARMS

A common alarm, which should be connected for all installations initiates on alarms functions described below. Three additional alarm relays are available for selectable functions as listed below. For further information see Section 4.2 and 4.3. Each relay has normally closed contacts. The contacts will open in alarm condition except for the optional horn function which operates with normally open contacts. All contacts are open when the power is off.

Relays are connected as follows:

Relay	Terminal Numbers
Common Alarm	29 & 30
Alarm 2	31 & 32
Alarm 3	33 & 34
Alarm 4	35 & 36

**Common Alarms** All of the following conditions will cause a common alarm -

- ADC Calibration Fail
- DAC Calibration Fail
- Sensor 1 Fail
- Sensor 2 Fail\*
- Heater 1 Fail
- Heater 2 Fail\*
- Sensor 1 TC Open
- Sensor 2 TC Open\*
- Aux. TC Open
- Reference Air Pump Fail
- Reference Air Pump Blocked
- Mains Frequency Check fail
- Probe Filter Blocked
- Burner bypass Switch on
- Watchdog Timer

The watchdog timer is a special alarm. It will force the common alarm to activate in the event of a microprocessor failure. There will not be an alarm message displayed, but the analyser will reset.

Alarms can be accepted by either pressing the alarm button (viewing the alarm messages), or by temporarily closing a switch connected to terminals 16 & 17, REM ALARM RESET.

**Alarm relay 2 to 4** Select any one or all of the following for each relay. Refer 5 to Section 5.5, set-up 49 to 58

- High carbon
- Low carbon
- Carbon Deviation High\*
- Probe under temperature
- Probe purge in progress
- Alarm horn function (Relay 4 only)

\* These alarms are only available if two sensors are selected

### 3.10 CONNECTING THE AUTOMATIC PURGE SYSTEM

#### CAUTION

The purge and calibration solenoid valves are supplied with mains voltage. This supply has electrical shock danger to maintenance personnel. Always isolate the analyser before working with the purge and calibration solenoid valves.

The on-line auto purge system is optional. For details on its operation refer to Sections 1.3, 1.4, 2.9 and 2.10.

To automatically sense a blocked probe filter, a pressure sensor should be connected to the 'purge' line to the probe 'cal' port. It should be adjusted so that it energises just above the purge pressure with a new or clean filter installed. The switch contacts should be connected to terminals 12 & 13 (PURGE FL SWITCH).

If the filter is still blocked or partly blocked after an auto purge cycle, the pressure switch will energise and cause a 'Probe Filter Blocked' alarm.



After installation the purge/cal system should be tested thoroughly for leaks. Any leaks can cause significant errors if the furnace is at negative pressure. If the furnace is at positive pressure, an outward leak can cause corrosion in the purge/cal system piping and fittings.

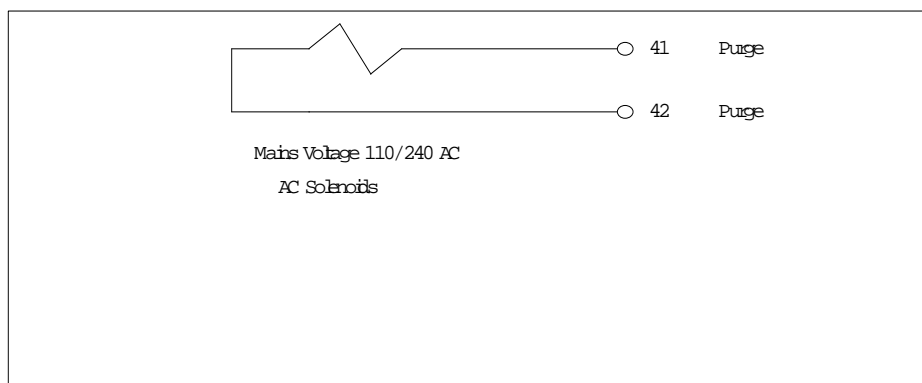

**Automatic Purge System Wiring Schematic**

### 3.11 CONNECTING REFERENCE AIR

For 1232 and 1233 carbon probes, there is a plastic tube integrated into the electrical probe cable which carries the reference air from the pump in the analyser to the probe. The reference air is passed to the probe through the centre pin of the electrical connector on the probe.

### 3.12 CONNECTING THE PRINTER

#### Serial Port Connections

A printer with a serial port, or a data logger, or a computer terminal may be connected to RS 232-C or the network port. Data is logged out of the port as arranged in Set-up steps 60 and 61. The baud rate is selectable in set-up step 62. The RS-232 protocol for the serial port is eight data bits, one stop bit, no parity.

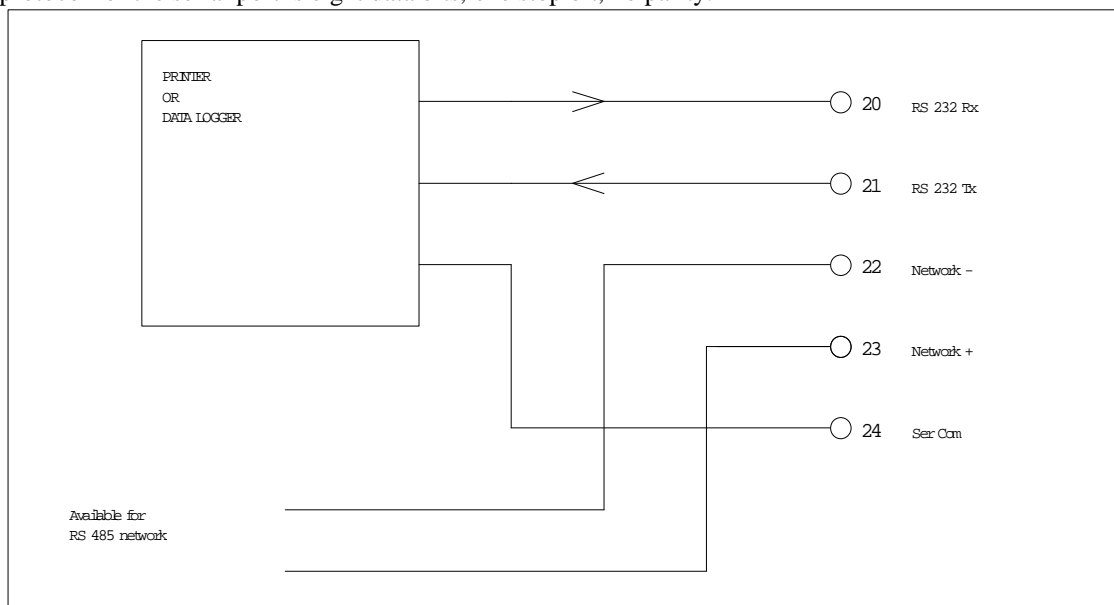

If the FURNACE MASTER control program is NOT being used, select 'NO' in set-up item 59, Remote Communications?

If the FURNACE MASTER control program is being used, select 'YES' in set-up item 59, Remote Communications?

### 3.13 CONNECTING THE CONTROL VALVES

If the 1634 is to be used as a controller, a control valve must be connected. The valve can either be a simple solenoid or a proportional valve.

For 'ON/OFF' control or 'Proportional ON/OFF', a simple solenoid can be used.

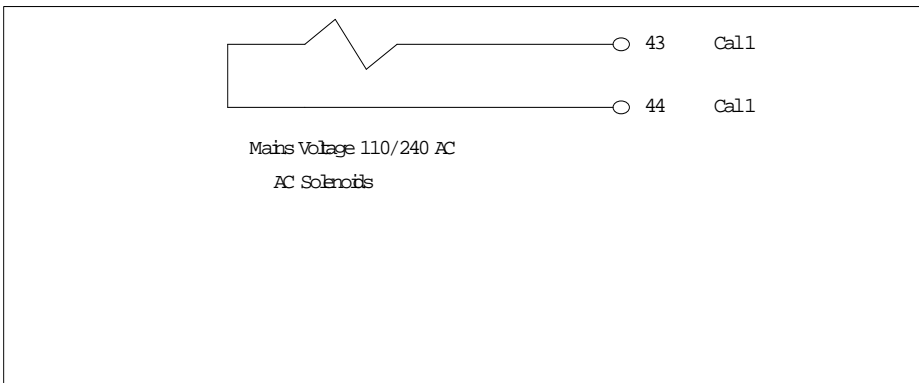

### Simple Solenoid Connections

If a motor driven up-down valve is to be used, select 'Proportional UP/DOWN' (or floating control).

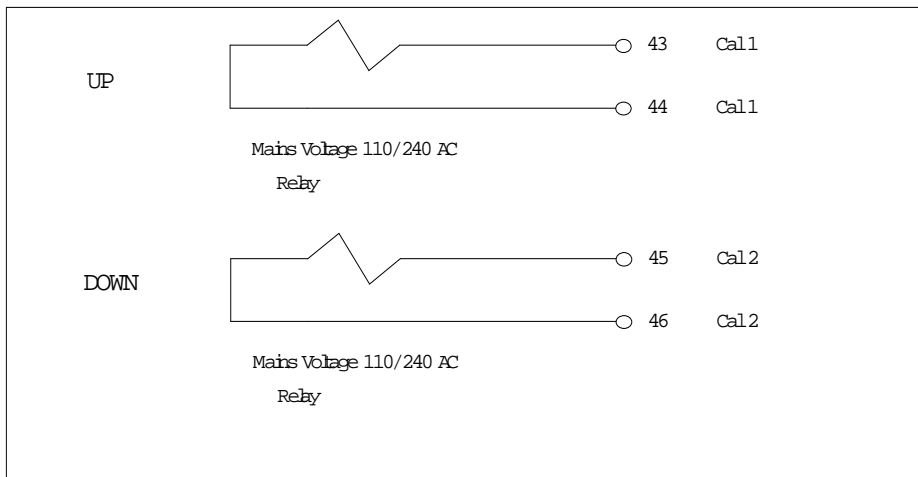

### Motor Drive UP/DOWN Connections

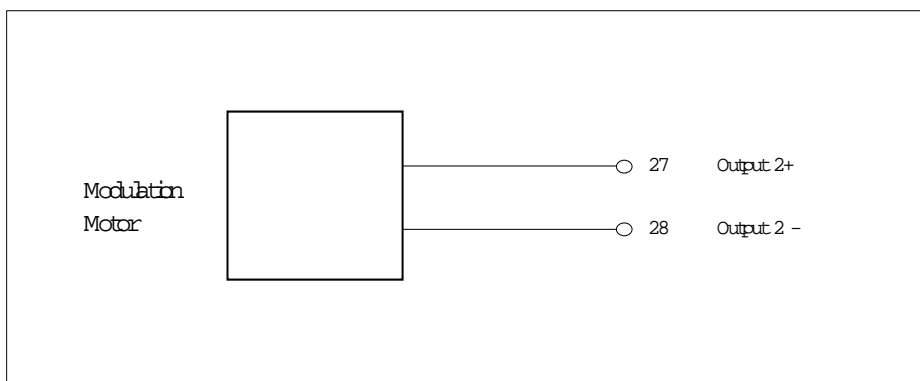

### Motor Drive UP/DOWN Connections

### 3.14 CONNECTING THE ANALYSER TO A MODBUS™ NETWORK

The analyser can be networked to other analysers and to a network master. The network uses the analyser RS485 port. Up to 31 analysers can be connected to the network, and can be interrogated by the Network Master.

*NOTE: Hardware Protocol Selection*

For the RS485 port on the analyser to operate, the link LK3 on the 1630-1 printed circuit board (mounted on the door of the analyser) must be set to the RS485 position. The LK3 is accessed by removing the cover from the door PCB. It is located at the bottom of the circuit board.

*NOTE: Terminating Resistor*

There is a terminating 100 ohm resistor fitted to the 1630-1 PCB. Link LK2, in the bottom left-hand corner of the PCB on the door, is used to connect the terminating resistor. Link LK2 must be removed on all analysers except the analyser on the end of the network line. If the network line from the analysers is taken from the middle of the analyser network string, a terminating resistor should be enabled with LK2 at each end of the network line.

The protocol of the network is –

Baud Rate	9600
Parity	none
Stop Bits	1
RS485	Half Duplex
Mode	RTU (binary mode)

For more details see Section 2.12 and Appendix 6.

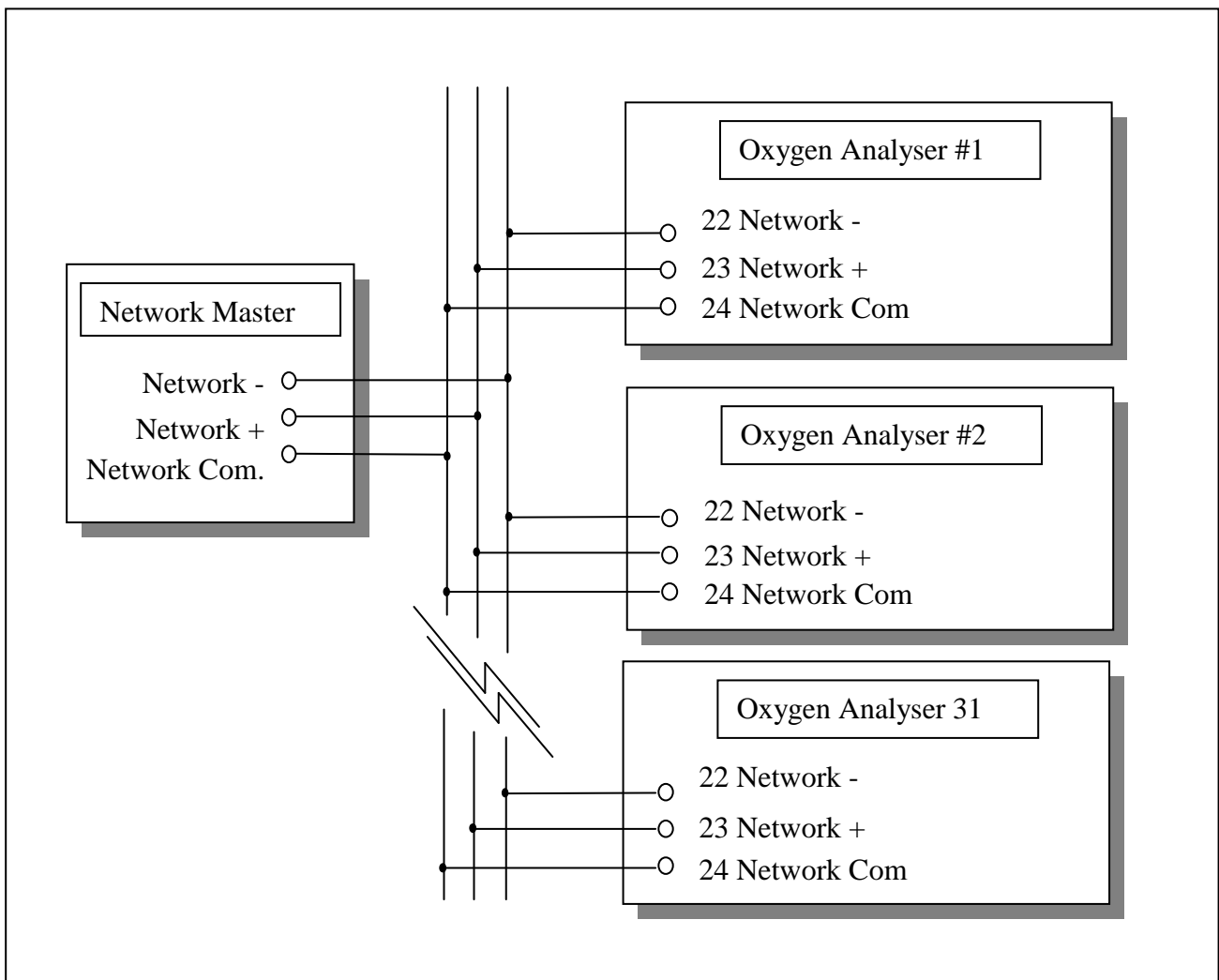

Network Connections

## COMMISSIONING

### 3.15 CONNECTING POWER

Before commissioning the probe or transmitter, check that the mains selector switch in the analyser is set to the correct voltage, and that the green/yellow EARTH wire is connected to earth.

It is recommended that, prior to commissioning, a 'COLD START' be performed. This resets all 'Set-up' and 'Maintenance' mode entries to their normal default values. 'COLD START' will show on the display for a second prior to a microprocessor initialising sequence, which takes about seven seconds.

After a 'COLD START', it is necessary to set all new variables in 'MAINTENANCE' and 'SET-UP' modes, including calibration voltages and time and date.

To perform a 'COLD START', see section 6.1.

A 'WARM START', which is performed by applying power with the cold start link in place, will retain all data previously entered in Maintenance and Set-up modes.

### 3.16 COMMISSIONING - SET-UP MODE

Press the SET-UP button to select the 'SET-UP' mode. Most of the default settings of the functions will be correct, or will have been pre-set at the factory. Refer to Section 5.5 for more details.

Check the following set-up functions -

2 to 6	Date /time
7 to 10	Reference voltages
11 & 12	Probe offset
22 & 23	Sensor type
26 to 28	Output channel #1
29 to 31	Output channel #2
38 to 42	Auto purge
49 to 58	Alarm set-up

### 3.17 COMMISSIONING - RUN MODE

When the analyser is turned on it will go to RUN mode. The SET-UP/RUN button will toggle between the two modes. The upper line of the display will now read 'CARBON %'. If the probe temperature is not above 650°C (1200°F), a "Probe Low Temperature" message is flashed on the lower line. The probe temperature can be checked on the lower line of the display.

### 3.18 CHECKING ALARMS

If any alarms are present the alarm LED will be lit, either flashing or steady. To interpret the alarms, press the alarm button until all alarm functions have been displayed. Rectify the cause of each alarm until no further alarms appear on the display. For details on the operation of the alarm button and the alarm functions refer to Section 4.

### 3.19 PROBE CALIBRATION

The zirconia sensor provides an absolute measurement of oxygen partial pressure. There are no calibration adjustments, apart from 'SENSOR OFFSET', for the probe. The probe EMF is either correct or replacement is required. To check that the probe is functioning correctly, firstly check that the high impedance alarm is not activate 'SENSOR FAIL' alarm. The actual impedance can be displayed on the lower line. It should be less than 6 KΩ at 900°C.

Once it has been established that the impedance is normal, the offset may be set using the millivolt level marked on the oxygen probe. Refer to Section 5.5.11. The probe offset can be tested on site. A small flow of air must be admitted to both the 'REF' and 'CAL' ports when testing the probe offset. If the probe is in the process, the air must fully purge the probe sensor without interference from the process gas sample. Novatech probes can easily achieve this with or without a probe filter and a gas flow of only about 0.5 litres per minute.

### **3.20 FILTER PURGING SET-UP PROCEDURE**

Purging probe filters is controlled from the 'PURGE' button on the analyser when in 'RUN' mode. If 'AUTO PURGE' has been enabled in set-up 38, pressing the PURGE button will start the automatic cycle. Pressing any other button will cancel the auto purge cycle. If AUTO PURGE was not enabled, the purge solenoid will only stay open for as long as the button is pressed. Gradually adjust the purge air supply regulator, increasing the pressure until sufficient flow is obtained to clear the filter. This is best checked with a dirty filter after a period of operation, by withdrawing the probe from service and watching any build up on the filter being blown off at the set pressure. Normally 30 kPa (5 psi) is adequate but the air pressure may be set as high as 100 kPa (15 psi).

The time between purges, purge duration and purge freeze time may be set in set-up steps 39 to 42 if 'YES' is selected in set-up step 38, (Automatic Purge).

### **3.21 SOOTING IN THE FURNACE**

For unheated probes with no filter, carbon build up in the end of the probe does not present a problem unless the carbon, when settled, is not porous. Allow the carbon in the process to build up on the probe. It will form a porous layer, slowing the response time. To avoid mechanical abrasion of the electrode material, pack 'SAFFIL' or equivalent alumina based ceramic fibre in the sensing holes to protect the electrode. Do not use silica based ceramic fibres such as 'KAOWOOL', which can attack the electrode at high temperatures. Once the carbon has built up the response time of the probe will be slower.

Probes can also be mounted horizontally with no filter. An occasional automatic back purge is helpful in this case.



# OPERATOR FUNCTIONS

## 4

### SECTION NUMBER

- 4.1 DISPLAY BUTTON
- 4.2 ALARM BUTTON
- 4.3 ALARM SCHEDULE
- 4.4 POWER LAMP
- 4.5 BURNER BYPASS SWITCH

## OPERATOR FUNCTIONS (RUN MODE)

### 4.1 DISPLAY BUTTON

The upper line on the display will always read % carbon for sensor 1. The following are available for display on the lower line.

1. Average of sensor 1 & sensor 2 carbon, \*\*
2. Sensor 2 carbon, \*\*
3. Sensor 1 EMF (millivolts)
4. Sensor 2 EMF (millivolts) \*\*
5. Sensor 1 temperature
6. Sensor 2 temperature \*\*
7. Sensor 1 impedance
8. Sensor 2 impedance \*\*

A measure of integrity of the sensor's electrode, the part of the probe that normally wears out first.

9. Auxiliary temperature
10. Ambient temperature
11. Ambient relative humidity
12. Controller Set Point
13. Date / time
14. Run hours since last service
15. Date of last service

\*\* Only available when the 2 probe option is available in Set-up 1

Any number of these variables can be displayed sequentially by pressing the 'DISPLAY' button. Items can be selected for display or deleted in Set-up step 35 on the keyboard. In addition to the above lower line displays, the analyser will automatically display:

"Sensor 1 Temp Low", when sensor one is below 650°C

"Sensor 2 Temp Low", when sensor two is below 650°C

"Purging Probe"

"Sensor 1 Thermocouple Wrong Polarity"

"Sensor 2 Thermocouple Wrong Polarity"

"Aux Thermocouple Wrong Polarity"

#### NOTE:

1. The run time will be the period of time the BURNER ON SWITCH (terminals 18 & 19) contact is closed (ie. main fuel valve open). If no explosion protection is required, a permanent bridge between the BURNER ON SWITCH terminals will register run time whenever the analyser is powered.
2. This timer can be used as a probe replacement and/or boiler service schedule aid. The start time is reset by changing the 'SERVICE DAY' in set-up mode on the keyboard.
3. If you hold the display button down as you switch on the power, the maximum ambient temperature which the instrument has been subjected to, will be displayed. This temperature should be less than 50°C.

### 4.2 ALARM BUTTON

Repeatedly pressing the 'ALARM' button will produce alarm displays in sequence on the lower line of the LCD display. If an alarm has cleared prior to pressing the 'ALARM' button, it will not re-appear on a second run through the alarms. Active alarms which have been previously displayed will have 'acc' (accepted in lower case), displayed alongside. New alarms will not have 'ACC' (in upper case) displayed until a second press of the 'ALARM' button. After the last active alarm is indicated, the lower line of the display will return to the last displayed lower line variable. Alarms may also be accepted remotely by a temporary closure of a switch connected to terminal 16 & 17, 'REMOTE ALARM RESET'.

The alarm 'LED' will flash when there is an un-accepted alarm. Pressing the 'ALARM' button will cause the LED to go steady if any alarms are still active, or extinguish if there are no active alarms. The horn relay will operate when an



alarm occurs. Pressing 'ALARM' will mute a horn relay (if one of the user configurable relays have been selected as a 'Horn' relay) which will re-initiate on any new alarms.

### **4.3 ALARM SCHEDULE**

#### **4.3.1 SUMMARY OF ALARMS - COMMON ALARM**

1. 'Sensor 1 Fail'

2. 'Sensor 2 Fail'

Oxygen cell or electrode failure (high impedance); (inhibited under 650°C).

3. 'Heater 1 Fail'

4. 'Heater 2 Fail'

In the first 20 minutes of power being applied to the heater after being switched on, this alarm will not occur, but a 'Sensor # Lo Temp' display will occur and common alarm relay will be activated. Refer to Section 6.11. If an ADC alarm occurs, the heaters will automatically be turned off.

5. 'Sensor 1 TC Open'

6. 'Sensor 1 TC Open'

Probe thermocouple is open circuit.

7. 'Aux TC Open'

Auxiliary thermocouple is open circuit. If the thermocouple is not needed, select "NO T/C" for "Aux TC Type" or place a short circuit between terminals 5 & 6.

8. 'Ref Pump Fail'

The reference air pump in the analyser has failed.

9. 'Ref Pump Blocked'

The reference gas supply from the air pump in the analyser to the probe is blocked.

10. 'ADC Cal Fail'

The analog to digital converter has been found to fall outside the normal calibration specifications. In this case the sensor heater will automatically be turned off.

11. 'Mains Freq'

The sample of the mains frequency has failed.

12. 'DAC Cal Fail'

The digital to analog and voltage isolator circuit has been found to fall outside the normal calibration specifications. This check is only performed when the 'AUTO CAL' button is pressed. Refer to Section 6.3.

13. 'Probe Filter'

Blocked probe filter. This test is only performed when automatic purging of the probe is requested. Refer to step 38 in the set-up menu Section 5.5. This alarm will not reset until the next purge cycle which can be initiated manually or automatically.

14. 'Burner bypass'

The safety interlock relay has been bypassed by turning on the 'BURNER BYPASS' switch on the terminal printed circuit board. Refer to Section 4.5.

15. 'Watchdog Timer'

Microprocessor error. This alarm will not appear on the display. The common alarm relay will be forced open circuit. If the watchdog timer senses a malfunction in the microprocessor, it will attempt to reset the analyser every 2 seconds. After two resets the alarm relay contacts will go open circuit.

16. 'BB RAM Fail'

The battery backed memory module has failed in service. The device normally lasts 10 years. It is the plug-in battery like module on the 1630 -1 board, labelled M1.

#### **4.3.2 SUMMARY OF ALARMS - SELECTABLE ALARMS**

There are three user configurable alarm relays. Any or all of the following functions can be selected for each relay.

17. 'Carbon% Low'

The measured carbon level is below the level set in set-up 52, and the alarm delay set in SET-UP 53 has expired. See Section 5.5.52 for more details.

18. 'Carbon % High'

The measured carbon level is above the level set in set-up 50, and the alarm delay set in set-up 51 has expired. See Section 5.5.50 for more details.

19. 'Carbon Deviation High'

The carbon as read by probe 1 differs from the carbon read by probe 2 by an amount greater than the level set in set-up 54, for a period longer than that set in set-up 55. This alarm is only available if 'Two Sensors' is selected in set-up 1.

20. 'Probe Temperature'

The probe temperature is under 650°C. The oxygen and carbon readings are therefore invalid.

NOTE:

The 'Probe Temp' relay function is used with unheated probes to indicate oxygen and carbon reading is invalid (the probe is below 650°C), in case the process temperature falls below this level. For heated probes this relay will be energised while the probe is heating up from ambient.

21. Probe Purge

A probe purge is occurring, either manual ( in RUN mode) or automatic

22. Alarm Horn

This is not an alarm condition. If one of the three user configurable alarm relays have 'Alarm Horn' enabled, the relay will have closed contacts only when there is an unaccepted alarm on the analyser. Press the alarm button twice to accept any new alarm and to cancel the horn relay. This is only available on relay 4.

### 4.3.3 ALARM RELAYS

The alarm relays are fail safe. That is, the contacts will be closed during normal operation, and will be open circuit if there is an alarm or if the power is removed from the analyser.

### 4.4 POWER LAMP

Illuminates when power is connected to the analyser. If the lamp is flashing, the watchdog timer is attempting to reset the microprocessor. Replace the 1630-1 microprocessor PCB.

### 4.5 BURNER BYPASS SWITCH

This switch is mounted on the terminal PCB near the POWER switch.

To enable the process alarms, there must be a link on the safety interlock on terminals 18 & 19 (BURNER ON switch), or press the BURNER BYPASS switch to the ON position. While the BURNER BYPASS switch is on there will be an alarm, "Burner Bypass".

If it is not needed to have the analyser interlocked with the combustion appliance terminals 18 & 19 can be connected together.

# SETTING UP THE ANALYSER

## 5

### SECTION NUMBER

- 5.1 SET-UP MODE SUMMARY
- 5.2 SET-UP & RUN MODES
- 5.3 FUNCTION SELECT
- 5.4 ENTER OPTION OR VALUE
- 5.5 SET-UP FUNCTION DETAILS

## SET-UP MODE SUMMARY

### 5.1 SET-UP MODE FUNCTIONS

- 1 Number of Sensors
- 2 Calender Year
- 3 Calender Month
- 4 Calender Day
- 5 Real time clock Hour
- 6 Real time clock Minutes
- 7 Reference voltage #1
- 8 Reference voltage #2
- 9 Reference voltage #3
- 10 Reference voltage #4
- 11 Sensor 1 offset
- 12 Sensor 2 offset
- 13 Output channel number 1 calibration
- 14 Output channel number 1 calibration, 4mA trim
- 15 Output channel number 1 calibration, 20mA trim
- 16 Output channel number 2 calibration
- 17 Output channel number 2 calibration, 4mA trim
- 18 Output channel number 2 calibration, 20mA trim
- 19 Service record year
- 20 Service record month
- 21 Service record day
- 22 Sensor 1 Type
- 23 Sensor 2 Type
- 24 Sensor 1 Thermocouple Type
- 25 Sensor 2, Auxiliary Thermocouple Type
- 26 Transmitter Output Channel 1 scale
- 27 Transmitter Zero Channel 1
- 28 Transmitter Span Channel 1
- 29 Transmitter Output Channel 2 scale
- 30 Transmitter Zero Channel 2
- 31 Transmitter Span Channel 2
- 32 Generator Gas Selection
- 33 Furnace CO % value (Only available if Nitrogen/Methanol is selected in Set-up 32)
- 34 Centigrade/Fahrenheit Selection
- 35 Lower Line Display Functions
- 36 Flue Pressure mm/inches/kilopascals
- 37 Flue Pressure Value

- 38 Automatic Purge

Set-up steps 39 to 42 will be skipped automatically if 'No' is selected in set-up step 38.

- 39 Purge/Cal Time
- 40 Time Between Purges
- 41 Purge Duration
- 42 Purge Freeze Time

- 43 Carbon controller enable

Set-up steps 44 to 48 will be skipped automatically if depending on what is selected in set-up step 43.

- 44 Carbon controller set point
- 45 Carbon controller proportional band
- 46 Carbon controller dead band
- 47 Carbon controller reset action
- 48 Carbon controller cycle time

- 49 Process alarm enable

Set-up steps 50 to 55 will be skipped automatically if 'No' is selected in set-up step 49.

- 50 High carbon alarm level
- 51 High carbon alarm delay time

- 52 Low carbon alarm level
- 53 Low carbon alarm delay time
- 54 Carbon Deviation Alarm ( 2 probes)
- 55 Carbon Deviation Alarm Delay ( 2 probes)

- 56 Alarm relay number 2 function select
- 57 Alarm relay number 3 function select
- 58 Alarm relay number 4 function select

- 59 Remote Communications, Yes/No

Set-up steps 60 to 62 will be skipped automatically if 'Yes' is selected in set-up step 59.

- 60 Data to Print
- 61 Print Log Period
- 62 Printer Baud Rate

- 63 MODBUS™ Address
- 64 Damping factor

## 5.2 SET-UP & RUN MODES

For the SET-UP mode keyboard to operate, press the SET-UP/RUN button. The set-up light will come on when the set-up mode has been entered.

### NOTE:

Set-up mode cannot be entered if the keyboard lock switch on the inside of the analyser is in the UP position. The keyboard lock switch can be found on the door PCB (1630-2), on the lock side, at the top. If access is attempted while the keyboard is locked, the message '**Illegal Access**' will be displayed.

The temperature of a heated probe may fall if the set-up mode is used for more than 2 minutes.

While the analyser is in set-up mode the outputs will be frozen. All the of the functions written in BLUE will now operate. If there are not any buttons pressed for 1 minute the analyser will automatically revert to RUN mode.

If purges or an auto-calibration check occurs while the analyser is in set-up mode, they will be delayed until the analyser is returned to RUN mode.

To cancel an automatic purge or calibration check cycle, press AUTO CAL button while in RUN mode.

## 5.3 FUNCTION SELECT

When the SET-UP mode is entered, the analyser will automatically read the last set-up function selected.

To select other functions, operate the 'FUNCTION ▲' button to increment to the next function, or 'FUNCTION ▼' to decrement to the previous function.

## 5.4 ENTER OPTION OR VALUE

### A. Options.

To step through the available options for each function press the 'OPTION ▲' or 'OPTION ▼' buttons.

When the required option is selected press the 'ENTER' button. An asterisk will then appear alongside the option selected. When stepping through the set-up functions, the display will always first indicate the last options entered. The 'Lower Line Select' and 'Data To Print' set-up items 35 and 60 are multiple options. One or more options may be selected for these functions.

### B Values

To set a value for a particular function press the 'OPTION ▲' button to increase the value and the 'OPTION ▼' button to decrease the value. A momentary press will change the value one digit. Holding the button will change the value more quickly. Once the correct option or value is displayed it can be entered into the analyser's memory by pressing the 'ENTER' button. When a value has been entered an asterisk will appear at the R.H.S. of the lower line.

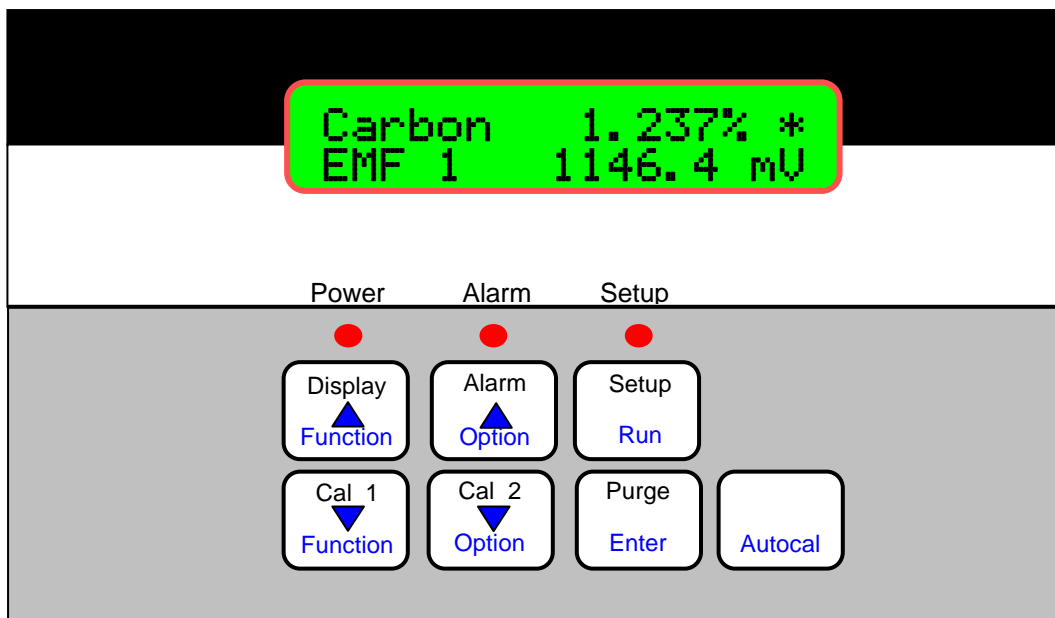

**1634 Oxygen Analyser Keyboard**

## 5.5 SET-UP FUNCTION DETAILS

**Note:** The \* indicates the default setting after a COLD-START. See Section 6.1

### 1. Number of sensors

#### Options

Select the number of oxygen probes being used.

- 1 Sensor \*
- 2 Sensors (Not available unless the 2 probe option is installed.  
Call your local agent or Novatech Controls for details.)

### 2. Calender year

#### Options

Select the current year for the real time clock/calender.

The cold start default sets the date and time to the software version date.

### 3. Calender month

#### Options

Select the current month for the real time clock/calender.

### 4. Calender day

#### Options

Select the current day for the real time clock/calender.

### 5. Real time clock hour

#### Options

Select the current hour for the real time clock. (24 hour format)

### 6. Real time clock minutes

#### Options

Select the current minutes for the real time clock.

### 7. Reference voltage # 1 ( about 27.5 mV's )

#### Options

Set the value of the reference voltage as read on a 3 1/2 digit multimeter (See Section 6.2 for further details).

27.55 mV \*

### 8. Reference voltage # 2 ( about 194 mV's )

#### Options

Set the value of the reference voltage as read on a 3 1/2 digit multimeter (See Section 6.2 for further details).

193.60 mV \*

## 9. Reference voltage # 3 ( about 1200 mV's )

### Options

Set the value of the reference voltage as read on a 3 1/2 digit multimeter (See Section 6.2 for further details).

1202.00 mV \*

## 10. Reference voltage # 4 ( about 2500 mV's )

### Options

Set the value of the reference voltage as read on a 3 1/2 digit multimeter (See Section 6.2 for further details).

2479.00 mV \*

Set-up items 7 to 10 are used to calibrate the A/D of the instrument. This should be done 30 minutes or more after the instrument has been on, approximately once every year. The calibration constants are retained in battery backed memory unless a 'COLD START' is performed. Connect a 3 1/2 digit multimeter negative lead to the test point marked 'C' to the right of the PCB on the inside of the door (labelled 'REF VOLTS'). Measure the four voltages on the test point marked 1 to 4 with the positive lead. Refer to Figure 6.2 in the 1634 manual. Enter the measured values in set-up items 7 to 10. Whenever new values are entered the D/A section should be re-calibrated, Refer to Section 6.3.

## 11. SET PROBE 1 OFFSET

### 12. SET PROBE 2 OFFSET (When 2 sensors are selected in set-up 1)

A new EMF offset must be entered whenever a new carbon probe is installed to calibrate for any offset an individual probe may have. Each probe will have an offset value noted on a removable tag. Enter the 'SENSOR OFFSET' value with the underline polarity,

eg. if offset value is -1.2 mV. enter -1.2 mV. The typical maximum is 2mV.

The probe offset voltage is set by reading the offset voltage from the label on the outside of the probe head, and entering this in set-up 11 for probe #1 and set-up 12 for probe #2.

It is difficult to check a probe offset on site with unheated probes because the probe must be sensing air on the outside of the probe, with reference air on the inside, and allowed to settle at the probe operating temperature for 30 minutes at the a temperature between 650 and 950 °C. This could be achieved in a tube furnace in a workshop.

This procedure has already been done in the Novatech factory before the probe was delivered. The sensor offset voltage at that time was written on the head label.

To determine the probe offset after the probe has reach, and stabilised at the operating temperature, select 'RUN' mode. Select 'Sensor EMF' on the lower line. With probe in free air, read the 'Sensor EMF'. Switch back to 'set-up' mode and enter 'Sensor Offset' of equal value and the same polarity.

eg. If the measured 'SENSOR OFFSET' was -1.2 mV, enter -1.2 mV.

When reading the EMF offset, the furnace pressure compensation must be set. If the probe has been removed from the furnace, set the furnace pressure compensation to 0 in set-up step 37, but remember to reset the pressure after the test.

## 13. 4 to 20 mA CALIBRATION OPTIONS, CHANNEL #1

Select the calibration method for the 4-20mA output channel #1.

The output channels can be either calibrated by simply pressing the 'AUTO CAL' button, or can be trimmed at both the 4mA and 20mA ends of the scale using an external multimeter.

### Options:

1. Auto Calibration \*
2. Manual Calibration
3. Set 4mA Trim
4. Set 20mA Trim

If 'AUTO CAL' is selected, the output channel is calibrated when 'Auto Cal' is initiated from the keyboard (See section 6.3).

If 'MAN CAL' is selected, it is necessary to trim both ends of the 4-20mA output range using the 4mA and 20mA options in this menu item. Selecting 'MAN CAL' inhibits the 'Auto Cal' process of this channel.

Always do the 4mA trim first, and then the 20mA trim. After trimming both ends of the scale, return the 'CALIBRATION OPTIONS' menu option back to 'MAN CAL' (not 'AUTO CAL'), or the calibration factors will be over written by the next 'AUTO CAL'.

For more details on calibrating the output channels, see section 6.3.

NOTE: If the analyser will only stay in either '4mA TRIM' or '20mA TRIM' modes for 30 minutes before it automatically returns to 'MAN AL'.

#### **14. CALIBRATE 4mA, CHANNEL #1**

This menu item only appears if 'Set 4mA Trim' is selected in Set-up 13.

**Range:** 0 to 25mA, Default is 4.00mA

For full details on the calibration of the 4-20mA output channels, see section 6.3.

#### **15. CALIBRATE 20mA, CHANNEL #1**

This menu item only appears if 'Set 20mA Trim' is selected in Set-up 13.

**Range:** 0 to 25mA, Default is 20.00mA

#### **16. 4 to 20 mA CALIBRATION OPTIONS, CHANNEL #2**

Select the calibration method for the 4-20mA output channel #1.

For more details, see Set-up 13 and section 6.3.

##### **Options:**

1. Auto Calibration \*
2. Manual Calibration
3. Set 4mA Trim
4. Set 20mA Trim

#### **17. CALIBRATE 4mA, CHANNEL #2**

This menu item only appears if 'Set 4mA Trim' is selected in Set-up 16.

**Range:** 0 to 25mA, Default is 4.00mA

For full details on the calibration of the 4-20mA output channels, see section 6.3.

#### **18. CALIBRATE 20mA, CHANNEL #2**

This menu item only appears if 'Set 20mA Trim' is selected in Set-up 16.

**Range:** 0 to 25mA, Default is 20.00mA

#### **19. ENTER SERVICE YEAR**

For a new 'DATE OF LAST SERVICE', enter the service 'YEAR'. This can represent the last time the probe was serviced or the last time the boiler was serviced. It is recommended that probes be refurbished every two years

#### **20. ENTER SERVICE MONTH**

Enter the current 'MONTH'.

#### **21. ENTER SERVICE DAY**

End the current 'DAY' of the month. Altering these values will reset the 'RUN TIME'.

#### **22. SENSOR TYPE**

#### **23. SENSOR TYPE**

##### **Options**

Model No. Enter the probe model number in use

- |                     |   |  |
|---------------------|---|--|
| 1. 1231/1234 Heated |   | Heated Probe   |
| 2. 1232 Unheated    | * | Unheated Probe   |
| 3. 1233 Unheated    |   | Unheated Probe for high sulphur applications (cermet sheath) |



## 24. PROBE 1 THERMOCOUPLE TYPE

## 25. PROBE 1 THERMOCOUPLE TYPE (When 2 sensors are selected in set-up 1)

### AUXILIARY THERMOCOUPLE TYPE (When 1 sensor is selected in set-up 1)

The probe can have either a type K, R, or N thermocouple as a sensor temperature detector. A 1231 probe or a 1234 sensor will always have a K thermocouple, and a 1232 will usually have an R thermocouple.

#### Options

- |           |   |  |
|-----------|---|--|
| 1. K      |   | Check in the manual Section 1                                  |
| 2. R      |   | for the probe model number.                                    |
| 3. N      |   | Enter the correct TC type.                                     |
| 4. T      |   | T, S and J types are selectable for the auxiliary thermocouple |
| 5. S      |   | if 1 sensor is selected in set-up 1.                           |
| 6. J      |   |  |
| 7. NO T/C | * | If no TC type is to be used for an Auxiliary use.              |

## 26. TRANSMITTER OUTPUT CHANNEL 1

Select the type of output required from Channel 1. Carbon for probe #1 is the most common output required.

If two probes are being used, select the average signal. If while two probe average is selected on channel #1, and either of the probes fail (Probe fail or Probe thermocouple open circuit), the other probe will automatically be selected.

The EMF from probe #1 can also be used to represent the carbon potential of a furnace.

#### Options:

1. Carbon average of probe 1 and 2 \*(When 2 sensors are selected in set-up 1)
2. Carbon probe 1 \*(When 1 sensor is selected in set-up 1)
3. Sensor EMF, probe 1

#### Range

0 to 1.5 %, fixed (Carbon ranges)

0 to 1300mV, adjustable (Sensor EMF)

## 27. TRANSMITTER ZERO CHANNEL 1

The output zero and span of Channel 1 is set in set-up steps 28 and 29. Range limits are shown below.

If "No Output" is selected the output will be set to zero mA, and the output will not be calibrated.

## 28. TRANSMITTER SPAN CHANNEL 1

Output	Zero Range	Span Range	Default Setting
CARBON% (Average probe 1 & 2)	0 fixed	1.5% Carbon fixed	
CARBON PROBE #1 %	0 fixed	1.5% Carbon fixed	
PROBE #1 EMF	0 to 1200 mV in 100 mV steps	100 to 1300 mV in 100 mV steps	0 to 1300 mV
NO OUTPUT	---	---	---

## 29. TRANSMITTER OUTPUT CHANNEL 2

Select transmitter output for output Channel 2.

#### Options:

1. Carbon probe #2
2. Probe EMF #1 \*
3. Probe EMF #2
4. Probe #1 temperature
5. Probe #2/auxiliary temperature
6. Logarithmic scale oxygen, 0.1 to 20 %
7.  $10^{-1}$  to  $10^{-30}$  % oxygen (for reducing conditions)
8. No Output

## 30. TRANSMITTER ZERO CHANNEL 2

The output zero and span of Channel 2 is set in set-up steps 30 and 31. Range limits are shown below. If “No Output” is selected the output will be set to zero mA, and the output will not be calibrated.

### 31. TRANSMITTER SPAN CHANNEL 2

Output	Zero Range	Span Range	Default Setting
CARBON PROBE #2 %	0 fixed	1.5% Carbon fixed	
PROBE #1 EMF	0 to 1200 mV in 100 mV steps	100 to 1300 mV in 100 mV steps	0 to 100 mV
PROBE #2 EMF	0 to 1200 mV in 100 mV steps	100 to 1300 mV in 100 mV steps	0 to 100 mV
PROBE #1 TEMPERATURE	0 to 100 °C in 100 ° C steps	100 to 1400 °C in 100 ° C steps	0 to 1300 °C
PROBE #1 TEMPERATURE	0 to 100 °C in 100 ° C steps	100 to 1400 °C in 100 ° C steps	0 to 1300 °C
LOG OXYGEN (see Note 1)	0.1 % oxygen fixed	20 % oxygen fixed	
REDUCING OXYGEN (see Note 2)	10 <sup>+2</sup> to 10 <sup>-25</sup> % oxygen in one decade steps, non overlapping	10 <sup>-5</sup> to 10 <sup>-30</sup> % oxygen in one decade steps. Min span five decades	10 <sup>-1</sup> to 10 <sup>-30</sup> %
NO OUTPUT	---	---	---

#### NOTE

- 1: For log oxygen scale details, Refer to Appendix 3.
- 2: Note that the reducing oxygen span is shown on the display as the exponent only. -1 represents 10<sup>-1</sup> % oxygen.

Set-up items 30 and 31 will not be shown if ‘Carbon probe #2’ is selected in set-up 29.

### 32. GENERATOR GAS

Select the source of the gas in the furnace.

#### Options:

1. Methane
2. Propane
3. Nitrogen/Methanol

#### Note

If option 3, nitrogen/methanol is *not* selected, set-up step 33 will be skipped.

### 33. FURNACE CO%

Enter the value of carbon monoxide present in the furnace. This may be measured by another instrument, or may be estimated.

#### Default Value

23.0%

### 34. CENTIGRADE/FAHRENHEIT SELECTION

Select whether displays and outputs are to be in ° Celsius or Fahrenheit

**Options:**

1. Celsius (Centigrade) \*
2. Fahrenheit

### 35. LOWER LINE DISPLAY FUNCTIONS

In the run mode the upper line on the LCD display will always read % oxygen. The lower line can be set to read one or more of the following. Select as many as are required to be displayed by pressing the 'ENTER' button. Those selected will have an asterisk displayed alongside.

**Options:**

1. Probe #2 carbon , see note 2
2. Average of probe #1 & probe #2 carbon, see note 2
3. Oxygen % probe #1
4. Oxygen % probe #2
5. Probe #1 EMF
6. Probe #2 EMF, see note 2
7. Probe #1 temperature
8. Probe #2 temperature, see note 2, Auxiliary temperature (see Note 1)
9. Probe #1 impedance
10. Probe #2 impedance, see note 2
11. Ambient temperature
12. Relative humidity
13. Controller Set Point
14. Date to time
15. Run hours since last service
16. Date of last service

If no lower line options are required then do not enter any. If options already selected are required to be deleted, select the required option and press the 'ENTER' button. The asterisk will be removed.

**NOTE**

1. A thermocouple must be connected to Terminals 5 and 6 to obtain a proper reading for the auxiliary temperature (Refer Section 3.5).
2. These options will not appear unless two sensors are selected in set up 1, and the two probe option is available.

### 36. FURNACE PRESSURE UNITS

Enter flue pressure, eg. 3 mm W.G.

**Options:**

- mm W.G. \*
- Kilopascals
- Inches W.G.

### 37. FURNACE PRESSURE VALUE

Enter flue pressure e.g. 3 mm WG. The default setting is 0

**Limits :**

- 2000 to +2000 mm W.G.
- 9 to +9 inches W.G.
- 200 to +200 kpa.

### 38. AUTOMATIC PURGE

If a furnace periodically soots the probe, it will be an advantage to periodically pass a small flow of air down the 'CAL' port of the probe. The outputs will be frozen during purging. If no purge is required, set-up steps 38 to 42 will be skipped.

**Options:**

- Yes
- No \*

### 39. PURGE/CAL TIME

Set the first purge to occur at the correct time-of-day. If purging is required, set the time of day the the first purge should occur. If neither purge nor auto calibration check is required, ignore this time setting.

**Range:**

0 to 23 hours in one hour steps. The default time is 12 noon.

#### **40. TIME BETWEEN PURGES**

Set the time between purges eg. a two hourly purge or a 100 hourly purge.

**Range:**

1 to 199 hours. Default setting is 24 hours.

#### **41. PURGE DURATION**

Set up purge duration to a number between three and ten seconds. The filter is actually purged in less than one second, but three seconds are required for the purge flow switch to check that the filter is not blocked.

**Range:**

0 to 10 seconds. Default setting is 10 seconds.

#### **42. PURGE FREEZE TIME**

After the purge period the transmitter output will remain fixed (frozen) for an adjustable period to allow the probe reading to return to the correct process level and avoid output 'bumps'. The freeze period time required will depend on the probe response time and thus its design, and whether it has a filter or not.

To determine the required freeze time, manually perform a purge while the plant is in operation and note the time required for the reading to return to the correct process level within approximately 0.5 % oxygen.

**Range:**

10 to 1000 seconds in ten second steps. Default setting is 60 seconds.

#### **43. CARBON CONTROLLER ENABLE**

The 1634 Carbon Analyser is also capable of controlling the carbon atmosphere of a furnace.

There are four ways to control the furnace. The first one (ON/OFF) is the simplest, but the most commonly used.

The next three require a more sophisticated control valve. For more details, see Section 2.3.

**Options:**

No Control \*

ON/OFF

Proportional ON/OFF

Proportional 4-20mA

Proportional UP/DOWN

#### **44. CARBON CONTROLLER SET POINT**

Available if any carbon control mode is selected in set-up 43.

For more details, see Section 2.3.

This is the carbon percentage that the 1634 Analyser/Controller will maintain when the controller is enabled in set-up 43.

**Range:**

0.01–2.00 %. The default setting is 1.20 %.

#### **45. CARBON CONTROLLER PROPORTIONAL BAND**

Available if one of the three proportional methods of control is selected in set-up 43.

For more details, see Section 2.3.

If one of the proportional control modes is enabled in set-up 43, this menu item provides an adjustment on the sensitivity of the control action. The smaller the proportional band number, the larger the output valve adjustment reaction will be to an atmosphere change.

**Range:**

0.01 –20.00 % carbon. The default setting is 0.50 %.

#### **46. CARBON CONTROLLER DEAD BAND**

Available if either 4-20mA or up/down proportional methods of control is selected in set-up 43.

For more details, see Section 2.3.

This menu item provides an adjustable range over which the motor will not be adjusted. It removes the repeated small movements of the motor when the furnace is near to the set point.

**Range:**

0.001 –0.100 % carbon. The default setting is 0.050 %.

**47. CARBON CONTROLLER RESET ACTION**

Available if proportional 4-20mA method of control is selected in set-up 43.

For more details, see Section 2.3.

If the reset action is set to zero the controller may control the carbon level away from the set point value.

**Range:**

-2.00 – +2.00 % carbon. The default setting is 0.00 %.

**48. CARBON CONTROLLER CYCLE TIME**

This menu item will not appear if 'No Control', 'ON/OFF' or 'Proportional 4-20mA' is selected in set-up 43. For more details, see Section 2.3.

Set this value when using 'Proportional ON/OFF' or 'Proportional UP/DOWN' control modes to match the 1634 controller to the furnace. Keep the time as long as possible (maintaining smooth control) to reduce the wear on the control valve.

**Range:**

1–100 Seconds. The default setting is 30 Seconds

**49. PROCESS ALARM ENABLE**

If process alarms are not required, 'NO' can be selected. There will not be any process related alarms generated, and all process alarms will be cancelled, if 'NO' is selected.

The process alarms are High carbon, Low carbon, and Carbon deviation.

**Options:**

Yes

No

\*

**50. HIGH CARBON ALARM**

Set the operating point for the high carbon alarm relay.

**Range:**

0.01 –2.00 % carbon. The default setting is 1.50 % carbon.

**51. HIGH CARBON DELAY**

Typically set at 20 seconds. This delay is to avoid nuisance alarms when the generator is undergoing transitions gas production which can cause it to deviate from the carbon set point, but recover quickly.

**Range:**

0–200 seconds. The default setting is 20 seconds.

**52. LOW CARBON ALARM**

Set the operating point for the low carbon alarm relay. Typically set at 2.0% carbon, depending on the burner, it can be used as a safety warning.

**Range:**

0.01 –2.00 % carbon. The default setting is 0.35 % carbon.

**53. LOW CARBON DELAY**

Typically set at 20 seconds.

**Range:**

0–200 seconds. The default setting is 20 seconds.

**54. CARBON DEVIATION ALARM ( Only available if '2 probes' is selected in set-up 1)**

If the difference between 2 probes running on an analyser is greater than the limit set here, the alarm will be triggered. This alarm could be used to give an on-line warning of a problem in one of the probes.

**Range:**

0.01 –2.00% carbon. The default setting is 2.0 % carbon.

**55. CARBON DEVIATION ALARM DELAY ( Only available if '2 probes' is selected in set-up 1)**

A 30 second delay in the activation of this alarm will usually be ample to cover any deviation due to short term stratification differences between the two probes.

**Range:**

0–200 seconds. The default setting is 30 seconds.

## 56. ALARM RELAY #2

Any or all of the following alarm functions may be used to activate the alarm relay. They may be selected or de-selected using the 'ENTER' buttons as in set-up step 35.

### Options :

1. Probe #1 under temperature
2. Probe #2 under temperature
3. Low carbon %
4. High carbon %
5. Carbon deviation between probe #1 and probe #2, (if 2 probes is selected in set-up 1)
6. Probe purge in progress

## 57. ALARM RELAY #3

Alarm relay #3 has the same functions available as alarm relay #2. See SET-UP 56.

## 58. ALARM RELAY #4

Alarm relay #4 has the same functions available as alarm relay #2. See SET-UP 56.

In addition an alarm horn function is also available.

If 'Horn' is selected it will override any other selections. A relay selected as a 'Horn' driver will have the relay contacts open circuit if there is an un-accepted alarm, and closed when a new alarm occurs.

## 59. REMOTE COMMUNICATIONS?

If the 1634 analyser is to be used in conjunction with a personal computer running 'Furnace Master', select 'YES'. This will inhibit all the printer output messages such as periodic data logs, or alarm messages. If 'YES' is selected, the 'REM COM' alarm will appear if no remote communication is received within 20 minutes. If you wish to use a printer, or computer for data logging, select 'NO'.

Options:

1. Yes
2. No \*

## 60. DATA TO PRINT

Any or all of the following values may be printed on a printer or computer connected to port 2. They may be selected or de-selected using the 'ENTER' buttons as in set-up step 35. The log period follows in set-up step 61. A sample of a printout is contained in Appendix 4.

RS 232C protocol is :

Data word length	Eight bits
Stop bits	One
Parity	None

Oxygen is always printed, plus any of the following :

### Options :

1. Probe #2 carbon , see note 2
2. Average of probe #1 & probe #2 carbon, see note 2
3. Oxygen % probe #1
4. Oxygen % probe #2
5. Probe #1 EMF
6. Probe #2 EMF, see note 2
7. Probe #1 temperature
8. Probe #2 temperature, see note 2, Auxiliary temperature (see Note 1)
9. Probe #1 impedance
10. Probe #2 impedance, see note 2
11. Ambient temperature
12. Relative humidity
13. Date to time
14. Run hours since last service
15. Date of last service

## 61. PRINT LOG PERIOD

Select the time interval between data print outs on the printer.

**Range:**

1 to 2000 minutes

## 62. PRINTER BAUD RATE

Select the correct BAUD rate for data to be transmitted out of the port to the printer.

**Options:**

300

1200

2400

4800

9600

## 63. MODBUS™ Address

This function is used when networking of one or more analyser back to a master computer or data acquisition system is required. For more details on the functions of the MODBUS™ see Section 2.12, and Appendix 6.

The valid range of MODBUS™ addresses is from 1 to 31. Any analyser with zero selected as the MODBUS™ address will have the MODBUS™ disabled, and the data log function enabled.

For the connection details, see Section 3.14.

**NOTE:** If the MODBUS™ address is changed, the analyser must be turned off and back on for the address change to take effect.

**Range:**

0-31 Default setting is 0.

## 64. DAMPING FACTOR

Each time a new reading is read from the carbon probe, the new reading is averaged with the last readings taken, before the new average is either displayed on the LCD, or sent to the 4 to 20 mA output. The number of readings that are averaged together is adjustable with this function. A value of five for example, means that the new reading from the probe and the previous four readings are averaged together before being displayed. A value of zero entered here will mean that every new reading from the probe will be sent to the display unaltered.

The smoothing of the oxygen signal is an exponential function. If a factor of 5 is used, a step change of input signal will take about 8 seconds to reach 63% of the change on the output/display.

**Range**

0 to 20. Default setting is 5.





# MAINTENANCE

## 6

### SECTION NUMBER

#### TRANSMITTER MAINTENANCE

- 6.1 COLD START
- 6.2 A/D CALIBRATION
- 6.3 D/A CALIBRATION
- 6.4 PUMP REPLACEMENT
- 6.5 BACK TO UP BATTERY REPLACEMENT
- 6.6 ELECTRONIC REPAIRS

#### PROBE & SENSOR MAINTENANCE

- 6.7 INSTALLING A NEW PROBE
- 6.9 TEST EQUIPMENT REQUIRED
- 6.10 TESTING A PROBE
- 6.11 PROBE THERMOCOUPLE

## TRANSMITTER MAINTENANCE

### 6.1 COLD START

A 'COLD START' will reset all 'Set-up' mode entries to their normal default values. 'COLD START' will show on the display for a second prior to a microprocessor initialising sequence, which takes about seven seconds.

After a 'COLD START', it is necessary to set all new variables in the 'SET-UP' mode, including calibration voltages and time and date.

#### To initiate a 'COLD START' -

Turn the mains power off

Remove the 'COLD START LINK' (this is located on the door PCB, next to the keyboard lock switch, behind the shield)

Turn the mains power on. The message "Cold Start....." will be displayed.

Leave the LINK off until the message "Replace c/s Link" is displayed. Replace the LINK.

The date and version number of the software will be displayed.

A 'WARM START', which is performed by applying power with the COLD START LINK in its place, will retain all data previously entered in the Set-up mode.

### 6.2 A/D CALIBRATION

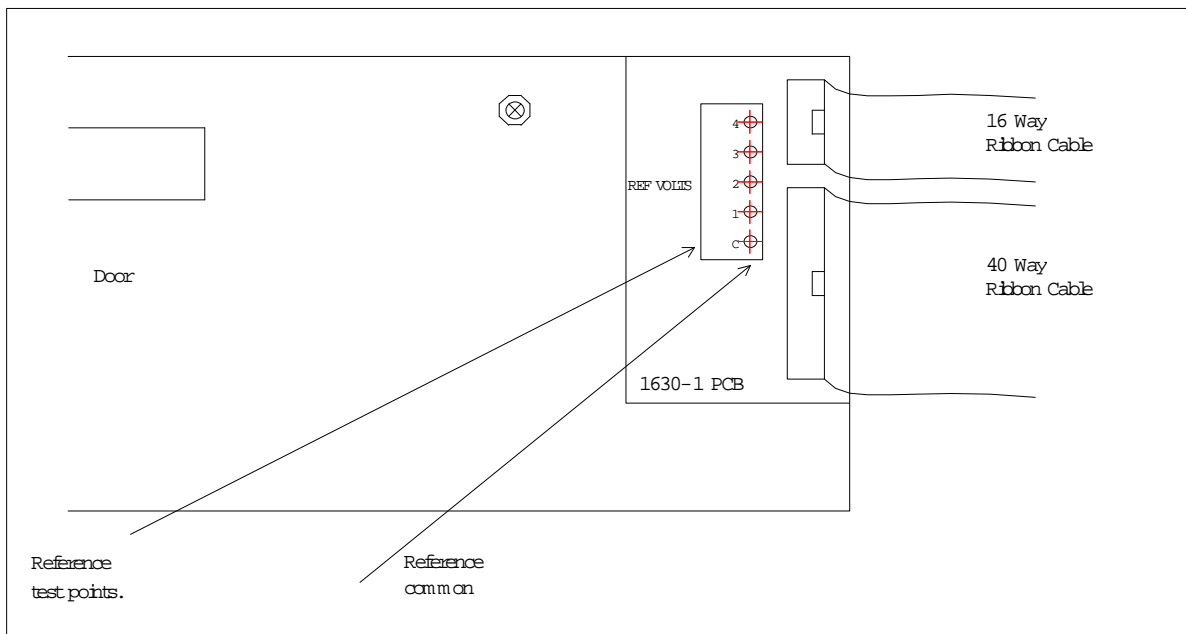

**Location of Calibration Test Points**

The analyser maintains its accuracy over a very long by continuously checking itself against internal stabilised references. The only calibration required is to set the actual values of these references into battery backed memory. The analyser will read these references every minute and update its zero and span correction factors. See Section 5.5.7 to 10. These references should be checked every 12 months. An AUTOCAL of the analog output section should always be performed if these references are altered. See Section 6.3.

### 6.3 D/A (4-20MA OUTPUT CHANNELS) CALIBRATION

The calibration can either be done using the 'Auto Cal' or 'Manual Cal'.

#### *Auto Cal*

The 'Auto Cal' mode is selected in set-up 13 (and 16 for channel 2).

The analyser will automatically divert the output back to the input, measure the offset and span, and record the calibration factors for each channel.

If either of the channels are selected to be calibrated manually, the factors will not be changed by an 'Auto Cal'.

#### *Manual Cal*

The 'Manual Cal' mode is selected in set-up 13 (and 16).

Set the 4mA calibration first and then the 20mA calibration.

1. Select 'Set 4mA Trim' in set-up 13 (or 16).

2. Return to RUN mode.
3. Measure the output on the channel to be calibrated with a digital multimeter. If the current is not exactly 4.00mA, return to set-up mode and change the 4mA calibration factor in set-up 14 (or 17).
4. Re-measure the current while back in RUN mode until the current is within 3.9 to 4.1mA.
5. Return to set-up mode and select 'Manual Cal' in set-up 13 (or 16).

Set the 20mA calibration factor.

6. Select 'Set 20mA Trim' in set-up 13 (or 16).
7. Return to RUN mode.
8. Measure the output on the channel to be calibrated with a digital multimeter. If the current is not exactly 20.00mA, return to set-up mode and change the 20mA calibration factor in set-up 15 (or 18).
9. Re-measure the current while back in RUN mode until the current is within 19.9 to 20.1mA.
10. Return to set-up mode and select 'Manual Cal' in set-up 13 (or 16).

This calibration is now saved in battery backed memory until

The factors are changed in the manual calibration

The analyser is forced into a COLD-START (see section 6.1)

The calibration mode in set-up 13 (or 16) is changed to Auto Cal and an Auto Cal is initiated.

**NOTE:** The 4mA or the 20mA trim mode will only be held on the output channels for 30 minutes before automatically returning to 'Manual Cal' mode in set-up 13 (or 16).

## 6.4 PUMP REPLACEMENT

The reference air pump is mounted on the 1630-2 PCB in the base of the analyser. The operation of the pump is monitored by the analyser and alarms will be shown if a fault occurs. ("Pump Fail" alarm, "Pump Blocked" alarm ) To replace the pump, unplug the 2 way pump power connector. The pump can now be un-screwed from the captive nuts on the circuit board.

## 6.5 BACK-UP BATTERY REPLACEMENT

The back-up battery is contained within the battery-like real time clock/memory module, plugged into socket M2. It is rated for an average service life of greater than ten years. The module is not re-chargeable and should be replaced every three years with a stored transmitters with power off or every eight years with a transmitters which have had the power on. The memory module must be purchased from Novatech Controls or an agent of Novatech Controls. After replacing the battery, re-enter all set-up mode functions.

## 6.6 ELECTRONIC REPAIRS

Electronic schematics are included in Appendix 5. A competent electronic technician could perform troubleshooting with these schematics, aided by the analyser self-diagnostic alarms. It is recommended that service be performed on a change-over circuit board basis. A fast turn-around or replacement service is available from Novatech or accredited service agents. Other service aids, including a test EPROM firmware package and probe input simulator are also available.

## 6.7 INSTALLING A NEW PROBE

Whenever a new carbon probe is installed, the millivolt offset value should be entered. To achieve this refer to set-up 11 (and 12 for the second probe).

The probe offset is noted on a tag or label attached to probe. To check an offset on site, the probe must be sensing air with reference air connected and allowed to settle at the operating temperature for 30 minutes. Read the offset in 'RUN' mode in millivolts on the lower line. Offset errors can occur if the sensor does not have some air passing over it. A gentle flow of air in the calibration check port can be provided by a reference air pump or similar. If a probe is in a process with the process running, the air purge on the sensing side of the sensor will only be successful if the probe has a filter or small sensing hole. Probes with open sensing ends or with large sensing holes allow the process gas to mix with the calibration gas, giving a false reading.

For unheated probes, the sensing tip must be raised to at least 650°C with a portable furnace.

## 6.8 TEST EQUIPMENT REQUIRED

All measurements are simplified if an analyser is connected to the probe. Readings can then be easily taken of probe impedance, EMF, temperature, percent oxygen and percent carbon.

The following tests are described using readily available workshop equipment where an analyser is not available. If an analyser is available the same test procedures will apply. First check all alarms on the analyser, allowing time for the probe to heat up after switch on.

An instrument to measure probe EMF and temperature is required. A 3 1/2 or 4 1/2 digit multimeter will perform both measurements.

A separate temperature indicator to suit the probe thermocouple type is also useful, although not necessary.

A reference air pump is required and a cylinder of calibration check gas e.g. 2 % oxygen in nitrogen. The cylinder should have a pressure and flow regulator. Both of these are inexpensive devices available from gas supply companies. The calibration check gas should be chromatograph tested to an accuracy of 0.05 % oxygen.

## **TEST EQUIPMENT FOR UNHEATED PROBES**

A small test furnace capable of raising the probe tip temperature to 720 °C is required. The furnace should have a uniform temperature for about 50 mm either side of the probe tip.

### **6.9 TESTING A PROBE**

With the probe heated to approximately 720 °C from a small test furnace, connect a digital multimeter to the probe electrode conductors. Connect the multimeter positive to the internal electrode conductor. Connect reference air to and apply a gentle purge of air to the probe calibration check port. Reference air flow should be the smallest flow available (less than 50 cc per minute). The multimeter should read zero millivolts  $\pm$  two millivolts. If not, then there is a problem with the probe electrodes and the sensor needs refurbishing. Normally a faulty probe electrode is indicated with a high source impedance.

To test the source impedance, set the multimeter to read ohms and take a measurement, within a couple of seconds, of the probe impedance. Reverse the multimeter and repeat the reading. Take the average of the two readings for an approximate measurement of impedance. If the impedance is above 10k $\Omega$ , then the probe needs to be replaced. The probe must be above 720 for this measurement. The reason that impedance measurements need to be performed quickly, is that the zirconia sensor polarises with the DC voltage from the multimeter across it.

If the probe tests reveal less than 2 mV offset and a good impedance reading, the next step is to apply a calibration check gas. The calibration check gas should be inserted in the calibration check port. With the calibration check gas flowing, the probe should develop an EMF according to the tables in Appendix 2. If the EMF reading is low then there may be insufficient calibration check gas flow. Increase the calibration check gas until the reading is correct. An excessive calibration check gas flow will cause cooling on one surface of the sensor, giving temperature differential errors on the sensor.

As an alternative, using the reference air port, the calibration check gas can be inserted into the inside of a probe sensor. This requires a lower flow rate, and thus lower usage of calibration check gas. The flow rate should be similar to that of the reference air, which should be removed for internal calibration check. The probe EMF reading will be identical but negative in polarity. A small flow of air should be flowing over the outside of the sensor, when testing in this way.

Occasionally, a sensor can develop offset with a polluted electrode caused by contaminants in the furnace gas stream. In this case the impedance may be OK but the output incorrect. This phenomenon is rare.

### **6.10 PROBE THERMOCOUPLE**

Although some unheated probes are specified without a thermocouple, most probes, both heated and unheated, have an integral thermocouple which is fitted in to the four bore insulator. The analyser has an alarm function which will advise the operator of an open circuit thermocouple, however bench testing can be performed by simply measuring the thermocouple continuity.

# APPENDICES

1. PROBE EMF TABLES FOR ENDOTHERMIC ATMOSPHERES
2. % OXYGEN SCALE TO LOGARITHMIC
3. SAMPLE LOG PRINT OUT
4. CIRCUIT SCHEMATICS



# APPENDIX 1

## PROBE EMF TABLES FOR ENDOTHERMIC ATMOSPHERES





# APPENDIX 2

## % OXYGEN LINEAR SCALE to LOGARITHMIC SCALE

% OXYGEN	% FULL SCALE
0.1	0
0.15	7.66
0.2	13.1
0.3	20.7
0.4	26.2
0.6	33.8
0.8	39.2
1	43.5
1.5	51.1
2	56.5
3	64.2
4	69.6
6	77.3
8	82.7
10	86.9
12	90.8
14	93.3
16	95.8
18	98
20	100



# APPENDIX 3

## SAMPLE LOG PRINT OUT

Novatech Controls 15-01-03 12:46:36

Carbon 1.224%  
Runtime 02:11  
Servc'd 15/01/03  
Oxygen 7.6E-20 %  
Oxygen2 1.6E-19  
Emf 1145.9mV  
Emf 2 mV 1132.1  
Sensor Deg 857C  
Sensor Imp 0.5K  
Sensr2 Imp 0K  
Ambient T 29C  
Ambient RH 54%

Purge 1433 Mins, Print Log 13 Mins,

12:09:55 20/04/03 Ref Pump Fail SELF CLEARED  
12:10:29 20/04/03 Low Carbon 1 ACCEPTED  
12:14:43 20/04/03 Probe 2 TC O/C  
12:17:46 20/04/03 Probe 2 TC O/C SELF CLEARED



# APPENDIX 4

## CIRCUIT SCHEMATICS







































# APPENDIX 5

## MODBUS™ Register Map and Application Notes

MODBUS™ Functions Supported are:-

ReadHolding Register Function 3  
WriteHolding Register Function 6 ( for allowable addresses only )

### Introduction.

The 1632 Analyser implements the MODBUS™ slave protocol, it is intended to work in conjunction with a MODBUS™ master.

This is accomplished by setting the MODBUS™ address to some non-zero value in the range 1-31, setting the jumper positions to select the RS485 half duplex configuration, and re-starting the analyser.

The master must be configured as follows.

Baud Rate	9600
Parity	none
Stop Bits	1
RS485	Half Duplex
Mode	RTU ( binary mode)

A typical transaction would be to read the current value of a variable from the analyser.

The master send a ReadHoldingRegister packet, with the appropriate address and the analyser responds with data at that address.

The Register Addresses are as follows, to convert to Schneider addresses for earlier model PLC's address space, add 40001 to each address.

or for later model PLC's with linear address space the address co-responds directly to %MW XXXX address.

For Example, to read probe temperature setpoint -

Read %MW1436 which is equivalent to holding register  $41437 = 40001 + 1436$

Some data is 32 bit data (double) which requires some care to ensure that the word order is correctly interpreted.

For Example, OXYGEN32, (dual probe) which is at address 2052 is interpreted as follows.

2052 contains the high 16 bits for probe 1 oxygen

2053 contains the low 16 bits for probe 1 oxygen

2054 contains the high 16 bits for probe 2 oxygen

2055 contains the low 16 bits for probe 2 oxygen





## Configuration and Setup Addresses

### *Holding*

<i>Reg.</i>	<i>Function</i>	<i>Description</i>
716	Probe #1 offset	10 = 1.0mV
717	Probe #2 offset	10 = 1.0mV

### Purge control related variables

754	Purge enable	0= off, 1= on
-----	--------------	---------------

### Calibration checking gas related variables

759	Gas calibration check	0= off, 1= 1 gas, 2= 2 gasses
2048	Probe #1 EMF	100,000 = 100.000 mV
2050	Probe #2 EMF	100,000 = 100.000 mV
2052	Probe #1 OXYGEN	100,000,000 = 100.0%
2054	Probe #2 OXYGEN	100,000,000 = 100.0%
2056	Probe #1 CARBON	100,000 = 100.0%
2058	Probe #2 CARBON	100,000 = 100.0%
2060	Probe #1, Impedance	1,000 = 1 k $\Omega$
2062	Probe #2, Impedance	1,000 = 1 k $\Omega$
2064	Probe #1 TC mV	100,000 = 100.000 mV
2066	Probe #2 TC mV	100,000 = 100.000 mV
2068	Probe #1 temperature	700 = 700 degC
2070	Probe #2 temperature	700 = 700 degC
2072	ALRM-ARRAY	Array of current alarm status. See below
2088	ALRM-TIMES	Array of timestamp of alarms

### Alarm array order -

1. Heater 1 fail
2. Sensor1 fail (Impedance too high)
3. Probe 1 filter blocked
4. Probe 1 thermocouple open circuit
5. Reference air Pump fail
6. Battery backed RAM fail
7. Mains frequency measurement fail
8. ADC warning (outside normal specifications, but still accurate)
9. DAC warning (outside normal specifications, but still accurate)
10. Carbon % low
11. Carbon % high
12. Oxygen % very Low
13. Carbon % deviation too high between oxygen probes
14. Oxygen % Deficient (oxygen % low on oxygen deficient range)
15. ADC Calibration fail
16. Gas 1 calibration error
17. Gas 2 calibration error
18. Burner bypass switch on
19. Aux thermocouple open circuit
20. Reference air pump fail
21. DAC Calibration fail
22. Probe Calibration
23. Heater 2 Fail
24. Sensor 2 Fail (Impedance too high)
25. Probe2 thermocouple open circuit
26. Probe temperature below 650 °C
27. Gas calibration check in Progress
28. Probe Purging
29. Alarm horn
30. Probe Temperature high



# Declaration of Conformity

**Application of Council Directives:**

89/336/EEC (92/31/EEC)  
72/23/EEC

**Standards to which conformity is declared:**

EN550011.1:1995 (ISM, Group 1, Class B)  
EN55014:1995 (Clause 4.2)  
EN50082-2 (Industrial)  
EN61010-1  
AS61000.4.5:1999  
IEC-68-2-2  
IEC-68-2-3  
AS1099.2.6

**Manufacturer's name:** **Novatech Controls Pty Ltd**

**Manufacturer's address:** 309 Reserve Road  
Cheltenham VIC 3192  
AUSTRALIA

**Type of equipment:** Oxygen Transmitter  
**Equipment Class:** ISM, Group 1, Class B  
**Model Number:** 1630 Series Transmitter  
1231 Oxygen Probe  
1234 Oxygen Sensor

---

*I hereby declare that the equipment specified herein conforms to the above directive(s) and standards(s).*



Full Name: **Fraser Chapman**  
Position: **R & D Manager**



**1. Interpretation**

In these conditions:

- (a) 'Seller' means Novatech Controls Pty. Ltd. ABN 57 006 331 700 of 309 Reserve Road, Cheltenham Victoria, 3192 which is the seller of the goods.
- (b) 'Buyer' means the buyer of the goods specified in the seller's quotation, or in the buyer's order for the goods.
- (c) 'Goods' means the products and, if any, services specified in Buyer's, orders or Seller's order acknowledgments from time to time.
- (d) Nothing in these conditions shall be read or applied so as to exclude, restrict or modify or have the effect of excluding, restricting or modifying any condition, warranty, guarantee, right or remedy implied by law (including the Trade Practices Act 1974) and which by law cannot be excluded, restricted or modified.

**2. General**

These conditions (which shall only be waived in writing signed by the seller) prevail over all conditions of the buyer's order to the extent of any inconsistency.

**3. Terms of sale**

The goods and all other products sold by the seller are sold on these terms and conditions.

**4. Seller's quotations**

Unless previously withdrawn, seller's quotations are open for acceptance within the period stated in them or, when no period is so stated, within 60 days only after its date. The seller reserves the right to refuse any order based on this quotation within 7 days after the receipt of the order.

**5. Packing**

The cost of any special packing and packing materials used in relation to the goods are at the buyer's expense notwithstanding that such cost may have been omitted from any quotation.

**6. Shortage**

The buyer waives any claim for shortage of any goods delivered if a claim in respect for short delivery has not been lodged with seller within seven (7) days from the date of receipt of goods by the buyer.

**7. Drawings, etc.**

- (a) All specifications, drawings, and particulars of weights and dimensions submitted to the buyer are approximate only and any deviation from any of these things does not vitiate any contract with the seller or form grounds for any claim against the seller.
- (b) Except as referred to in Clause 13.1 herein, the descriptions, illustrations and performances contained in catalogues, price lists and other advertising matter do not form part of the contract of sale of the goods or of the description applied to the goods.
- (c) Where specifications, drawings or other particulars are supplied by the buyer, the seller's price is made on estimates of quantities required. If there are any adjustments in quantities above or below the quantities estimated by seller and set out in a quotation, then any such increase or decrease are to be adjusted on a unit rate basis according to unit prices set out in the quotation.

**8. Performance**

Any performance figures given by the seller are estimates only. The seller is under no liability for damages for failure of the goods to attain such figures unless specifically guaranteed in writing. Any such written guarantees are subject to the recognised tolerances applicable to such figures.

**9. Acknowledgment regarding facilities for repairs or parts**

The buyer acknowledges that the seller does not promise or represent that facilities for the repair of the goods, or that parts of the goods are or will be available. The buyer must ensure that each purchaser of the goods from the buyer receives notice that the seller does not promise that facilities for the repair of the goods will be available; or parts for the goods will be available.

**10. Delivery**

- (a) The delivery times made known to the buyer are estimates only and the seller is not be liable for late delivery or non-delivery.
- (b) The seller is not be liable for any loss, damage or delay occasioned to the buyer or its customers arising from late or non-delivery or late installation of the goods.
- (c) The seller may at its option deliver the goods to the buyer in any number of instalments unless there is an agreement in writing between the parties to the effect that the buyer will not take delivery by instalments.
- (d) If the seller delivers any of the goods by instalments, and any one of those instalments is defective for any reason:
  - (i) it is not a repudiation of the contract of sale formed by these conditions; and
  - (ii) the defective instalment is a severable breach that gives rise only to a claim for compensation.

**11. Passing of risk**

Risk in the goods passes to the buyer upon the earlier of:

- (a) actual or constructive delivery of the goods to the buyer; or
- (b) collection of the goods from the seller or any bailee or agent of the seller by the buyer's agent, carrier or courier.

**12. Loss or damage in transit**

- (a) The seller is not responsible to the buyer or any person claiming through the buyer for any loss or damage to goods in transit caused by any event of any kind by any person (whether or not the seller is legally responsible for the person who caused or contributed to that loss or damage).
- (b) The seller must provide the buyer with such assistance as may be necessary to press claims on carriers so long as the buyer:
  - (i) has notified the seller and the carriers in writing immediately after loss or damage is discovered on receipt of goods; and
  - (ii) lodges a claim for compensation on the carrier within three (3) days of the date of receipt of the goods.

**13. Guarantee**

- 13.1 The seller's liability for goods manufactured by it is limited to making good any defects by repairing the defects or at the seller's option by replacement, within a period as specified in Seller's catalogues or other product literature for specified cases or not exceeding twelve (12) calendar months after the goods have been dispatched (whichever is the lesser period) so long as:
- (a) defects have arisen solely from faulty materials or workmanship;
  - (b) the damage does not arise from:
    - (i) improper adjustment, calibration or operation by the buyer;
    - (ii) the use of accessories including consumables, hardware, or software which

- were not manufactured by or approved in writing by the seller;
- (iii) any contamination or leakages caused or induced by the buyer;
- (iv) any modifications of the goods which were not authorised in writing by the seller;
- (v) any misuse of the goods by the buyer or anyone for whom the buyer has legal responsibility (including a minor);
- (vi) any use or operation of the goods outside of the physical, electrical or environmental specifications of the goods;
- (vii) inadequate or incorrect site preparation; and
- (viii) inadequate or improper maintenance of the goods.
- (ix) fair wear and tear of the product in an environment in respect of which the Seller has informed the Buyer in catalogues or other product literature that the period of usefulness of the product is likely to be shorter than twelve (12) months.
- (c) the goods have not received maltreatment, inattention or interference;
- (d) accessories of any kind used by the buyer are manufactured by or approved by the seller;
- (e) the seals of any kind on the goods remain unbroken; and
- (f) the defective parts are promptly returned free of cost to the seller.

13.2 The seller is not liable for and the buyer releases the seller from any claims in respect of faulty or defective design of any goods supplied unless such design has been wholly prepared by the seller and the responsibility for any claim has been specifically accepted by the seller in writing. In any event the seller's liability under this paragraph is limited strictly to the replacement of defective parts in accordance with para 13.1 of these conditions.

13.3 Except as provided in these conditions, all express and implied warranties, guarantees and conditions under statute or general law as to merchantability, description, quality, suitability or fitness of the goods for any purpose or as to design, assembly, installation, materials or workmanship or otherwise are expressly excluded. The seller is not liable for physical or financial injury, loss or damage or for consequential loss or damage of any kind arising out of the supply, layout, assembly, installation or operation of the goods or arising out of the seller's negligence or in any way whatsoever.

**14. Seller's liability**

- 14.1 The seller's liability for a breach of a condition or warranty implied by Div 2 of Pt V of the Trade Practices Act 1974 (other than s 69) is limited to:
- (a) in the case of goods, any one or more of the following:
    - (i) the replacement of the goods or the supply of equivalent goods;
    - (ii) the repair of the goods;
    - (iii) the payment of the cost of replacing the goods or of acquiring equivalent goods;
    - (iv) the payment of the cost of having the goods repaired; or
  - (b) in the case of services:
    - (i) the supplying of the services again; or
    - (ii) the payment of the cost of having the services supplied again.

14.2 The seller's liability under s 74H of the Trade Practices Act 1975 is expressly limited to a liability to pay to the purchaser an amount equal to:

- (a) the cost of replacing the goods;
- (b) the cost of obtaining equivalent goods; or
- (c) the cost of having the goods repaired, whichever is the lowest amount.

**15. Prices**

- (a) Unless otherwise stated all prices quoted by vendor are net, exclusive of Goods and Services Tax (GST) and the buyer agrees to pay to the seller any GST in addition to the price.
- (b) Prices quoted are those ruling at the date of issue of quotation and are based on rates of freight, insurance, customs duties, exchange, shipping expenses, sorting and stacking charges, cartage, the quotation, cost of materials, wages and other charges affecting the cost of production ruling on the date is made.
- (c) If the seller makes any alterations to the price of the goods or to any of their inputs either before acceptance of or during the currency of the contract, these alterations are for the buyer's account.

**16. Payment**

The purchase price in relation to goods is payable net and payment of the price of the goods must be made on or before the thirtieth day from the date of invoice unless other terms of payment are expressly stated in these conditions in writing.

**17. Rights in relation to goods (Romalpa clause)**

The seller reserves the following rights in relation to the goods until all accounts owed by the buyer to the seller are fully paid:

- (a) ownership of the goods;
- (b) to enter the buyer's premises (or the premises of any associated company or agent where the goods are located) without liability for trespass or any resulting damage and retake possession of the goods; and
- (c) to keep or resell the goods including any goods repossessed pursuant to 17(b) above;

If the goods are resold, or goods manufactured using the goods are sold, by the buyer, the buyer shall hold

such part of the proceeds of any such sale as represents the invoice price of the goods sold or used in the manufacture of the goods sold in a separate identifiable account as the beneficial property of the seller and shall pay such amount to the seller upon request. Notwithstanding the provisions above the seller shall be entitled to maintain an action against the buyer for the purchase price and the risk of the goods shall pass to the buyer upon delivery.

**18. Buyer's property**

Any property of the buyer under the seller's possession, custody or control is completely at the buyer's risk as regards loss or damage caused to the property or by it.

**19. Storage**

The seller reserves the right to make a reasonable charge for storage if delivery instructions are not provided by the buyer within fourteen days of a request by the seller for such instructions. The parties agree that the seller may charge for storage from the first day after the seller requests the buyer to provide delivery instructions.

**20. Returned goods**

- (a) The seller will not be under any duty to accept goods returned by the buyer and will do so only on terms to be agreed in writing in each individual case.
- (b) If the seller agrees to accept returned goods from the buyer under para (a) of this clause, the buyer must return the goods to the seller at the seller's place of business referred to at the head of these conditions.

**21. Goods sold**

All goods to be supplied by the seller to the buyer are as described on the purchase order agreed by the seller and the buyer and the description on such purchase order modified as so agreed prevails over all other descriptions including any specification or enquiry of the buyer.

**22. Cancellation**

No order may be cancelled except with consent in writing and on terms which will indemnify the seller against all losses.

**23. Indemnity**

The buyer indemnifies on a continuing basis on a fully indemnity basis the seller from and against any

liability, loss, expense or demand for or arising from any false, misleading, deceptive or misdescriptive representation or statement made by the buyer in respect of the goods to any person. This indemnity survives termination of this agreement by either part for any reason.

**24. Exclusion of representations and arrangements**

Except as referred to in Clause 13.1 herein, these terms and conditions supersede and exclude all prior and other discussions, representations (contractual or otherwise) and arrangements relating to the supply of the goods or any part of the goods including, but without limiting the generality of the foregoing, those relating to the performance of the goods or any part of the goods or the results that ought to be expected from using the goods.

**25. No waiver**

The failure of any part to enforce the provisions of this agreement or to exercise any rights expressed in this agreement is not to be a waiver of such provisions or rights and does not affect the enforcement of this agreement.

**26. Force Majeure**

If by reason of any fact, circumstance, matter or thing beyond the reasonable control of the seller, the seller is unable to perform in whole or in part any obligation under this agreement the seller is relieved of that obligation under this agreement to the extent and for the period that it is so unable to perform and is not liable to the buyer in respect of such inability.

**27. Buyer Acknowledgement**

The Buyer acknowledges that the above provisions of these Conditions of Sale are reasonable and reflected in the price and the Buyer accepts the risks of the Buyer associated with these Conditions of sale and/or shall issue accordingly.

**28. Place of contract**

- (a) The contract for sale of the goods is made in the state of Victoria Australia.
- (b) The parties submit all disputes arising between them to the courts of such state and any court competent to hear appeals from those courts of first instance.